

1, 2 and 3 Axis Magnetic Sensors

HMC1051/HMC1052L/HMC1053

The Honeywell HMC1051Z, HMC1051ZL, HMC1052L and HMC1053 are magnetoresistive sensors designed for low field magnetic sensing. Various packaging options have been created from the basic HMC1052 sensor chip to create 1, 2 and 3-axis magneto-resistive sensors for cost effective and small size solutions. The advantage of the HMC105X family of sensors is in the near-perfectly orthogonal dual sensor on a single chip with shared set/reset and offset coils/straps included.

The HMC105X family utilizes Honeywell's Anisotropic Magnetoresistive (AMR) technology that provides advantages over coil based magnetic sensors. They are extremely sensitive, low field, solid-state magnetic sensors

designed to measure direction and magnitude of Earth's magnetic fields, from 120 micro-gauss to 6 gauss. Honeywell's Magnetic Sensors are among the most sensitive and reliable low-field sensors in the industry. Applications for the HMC105X family of sensors include low cost Compassing, Magnetometry, and Current Sensing.

Honeywell continues to maintain product excellence and performance by introducing innovative solid-state magnetic sensor solutions. These are highly reliable, top performance products that are delivered when promised. Honeywell's magnetic sensor solutions provide real solutions you can count on.

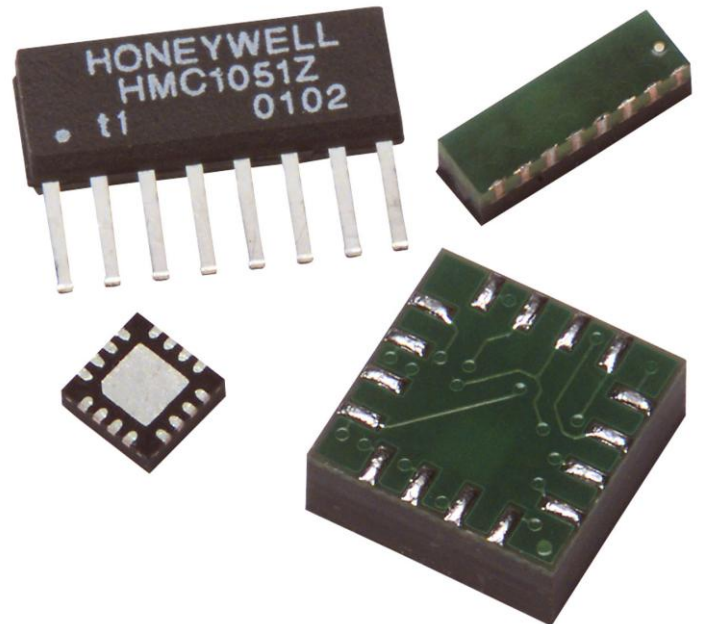

FEATURES

- ▶ Miniature Surface-Mount Packages
- ▶ Leaded and Leadless Packages
- ▶ Low Voltage Operations (1.8V)
- ▶ Low Cost
- ▶ Tape & Reel Packaging Options
- ▶ 4-Element Wheatstone Bridge
- ▶ Wide Magnetic Field Range (+/-6 Oe)
- ▶ Patented Offset and Set/Reset Straps

BENEFITS

- ▶ Small Sizes for Compact Applications
- ▶ Compatible with High Speed SMT Assembly and Prototyping
- ▶ Compatible for Battery Powered Applications
- ▶ Designed for High Volume, Cost Effective OEM Designs
- ▶ High Volume OEM Assembly
- ▶ Low Noise Passive Element Design
- ▶ Sensor Can Be Used in Strong Magnetic Field Environments
- ▶ Stray Magnetic Field Compensation

HMC1051/HMC1052/HMC1053

SPECIFICATIONS

Characteristics	Conditions*	Min	Typ	Max	Units
Bridge Elements					
Supply	Vbridge referenced to GND	1.8	3.0	20	Volts
Resistance	Bridge current = 10mA	800	1000	1500	ohms
Operating Temperature	Ambient	-40		125	°C
Storage Temperature	Ambient, unbiased	-55		150	°C
Humidity	Tested at 85°C			85	%
Field Range	Full scale (FS) – total applied field	-6		+6	gauss
Linearity Error	Best fit straight line ± 1 gauss ± 3 gauss ± 6 gauss		0.1 0.5 1.8		%FS
Hysteresis Error	3 sweeps across ±3 gauss		0.06		%FS
Repeatability Error	3 sweeps across ±3 gauss		0.1		%FS
Bridge Offset	Offset = (OUT+) – (OUT-) Field = 0 gauss after Set pulse	-1.25	± 0.5	+1.25	mV/V
Sensitivity	Set/Reset Current = 0.5A	0.8	1.0	1.2	mV/V/gauss
Noise Density	@ 1kHz, Vbridge=5V		50		nV/sqrt Hz
Resolution	50Hz Bandwidth, Vbridge=5V		120		μgauss
Bandwidth	Magnetic signal (lower limit = DC)		5		MHz
Disturbing Field	Sensitivity starts to degrade. Use S/R pulse to restore sensitivity.	20			gauss
Sensitivity Tempco	T _A = -40 to 125°C, Vbridge=5V T _A = -40 to 125°C, Ibridge=5mA	-3000	-2700 -600	-2400	ppm/°C
Bridge Offset Tempco	T _A = -40 to 125°C, No Set/Reset T _A = -40 to 125°C, With Set/Reset		± 500 ± 10		ppm/°C
Bridge Ohmic Tempco	Vbridge=5V, T _A = -40 to 125°C	2100	2500	2900	ppm/°C
Cross-Axis Effect	Cross field = 1 gauss, Happlied = ±1 gauss		9		%FS
Max. Exposed Field	No perming effect on zero reading			10000	gauss
Sensitivity Ratio of X,Y Sensors	T _A = -40 to 125°C (HMC1052 Only)	95	100	105	%
X,Y sensor Orthogonality	Sensitive direction in X and Y sensors (HMC1052)			0.01	degree

Set/Reset Strap

Resistance	Measured from S/R+ to S/R-	3	4.5	6	ohms
Current	0.1% duty cycle, or less, 2μsec current pulse	0.4	0.5	4	Amp
Resistance Tempco	T _A = -40 to 125°C	3300	3700	4100	ppm/°C

Offset Straps

Resistance	Measured from OFFSET+ to OFFSET-	12	15	18	ohms
Offset Constant	DC Current Field applied in sensitive direction		10		mA/gauss
Resistance Tempco	T _A = -40 to 125°C	3500	3900	4300	ppm/°C

* Tested at 25°C except stated otherwise.

HMC1051/HMC1052/HMC1053

PIN CONFIGURATIONS

(Arrow indicates direction of applied field that generates a positive output voltage after a SET pulse.)

HMC1051Z

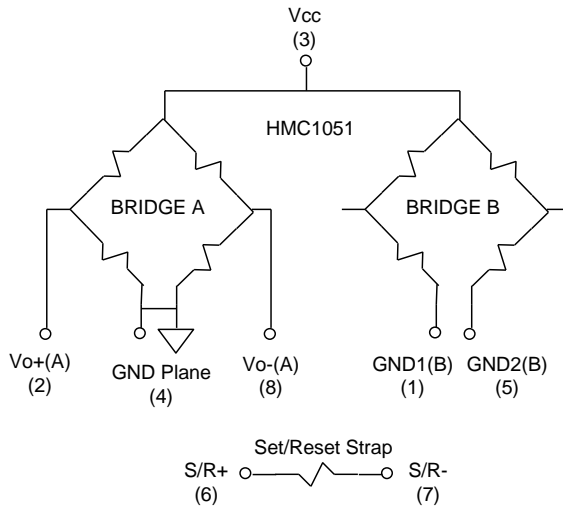

HMC1051Z Pinout

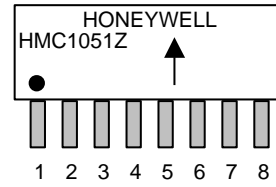

HMC1051ZL

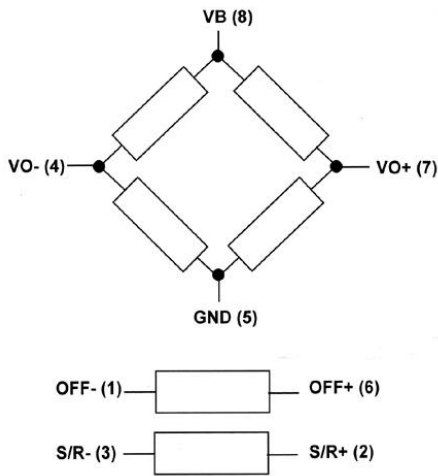

HMC1051ZL Pinout

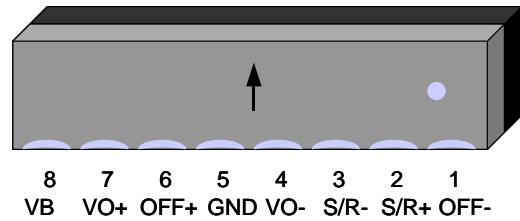

HMC1052L

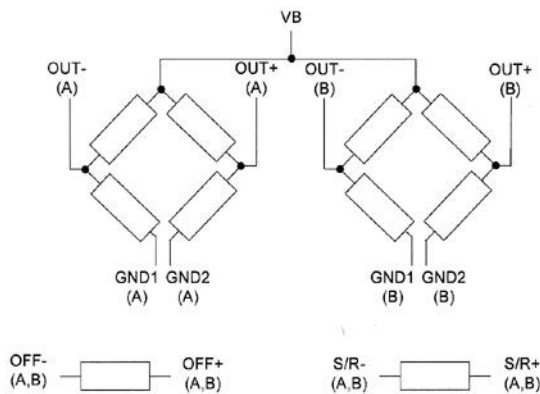

HMC1052L Pinout

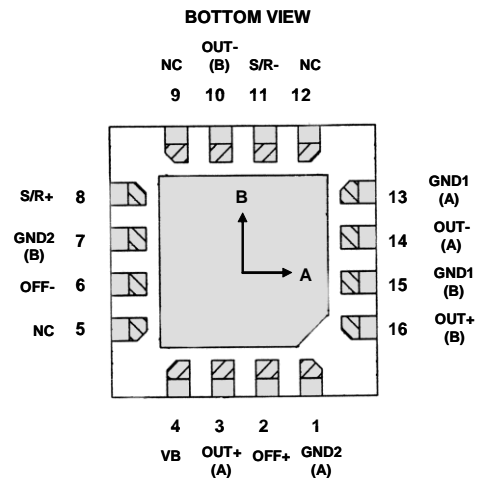

HMC1051/HMC1052/HMC1053

HMC1053

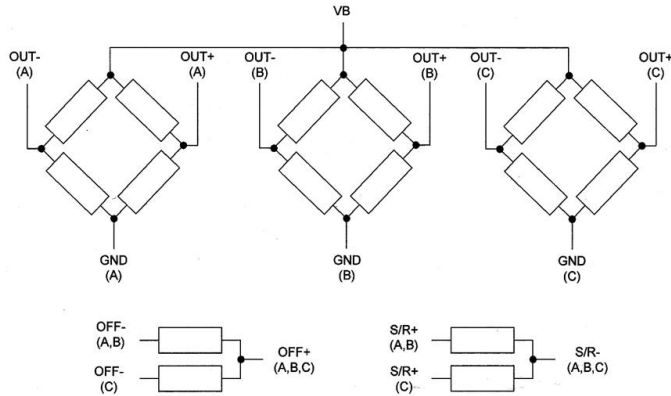

HMC1053 Pinout

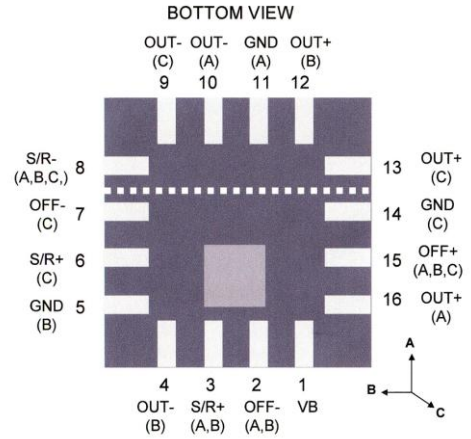

PACKAGE OUTLINES

PACKAGE DRAWING HMC1051Z (8-PIN SIP)

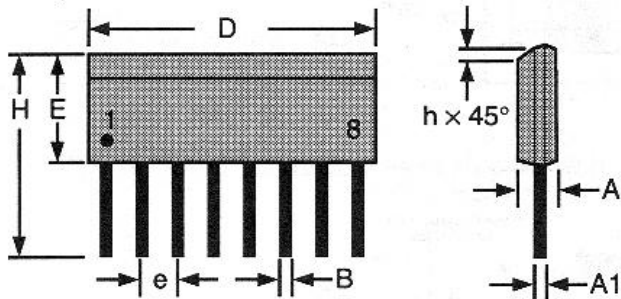

Symbol	Millimeters		Inches x 10E-3	
	Min	Max	Min	Max
A	1.371	1.728	54	68
A1	0.101	0.249	4	10
B	0.355	0.483	14	19
D	9.829	11.253	387	443
E	3.810	3.988	150	157
e	1.270 ref		50 ref	
H	6.850	7.300	270	287
h	0.381	0.762	15	30

PACKAGE DRAWING HMC1051ZL (8-PIN IN-LINE LCC)

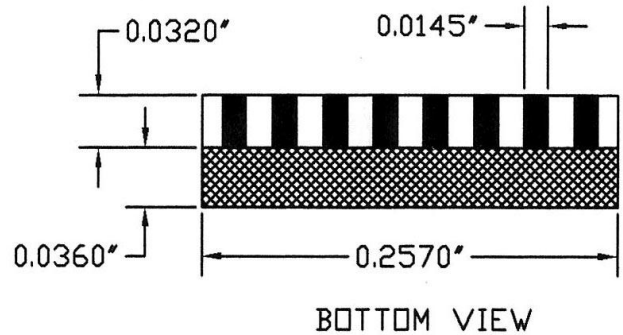
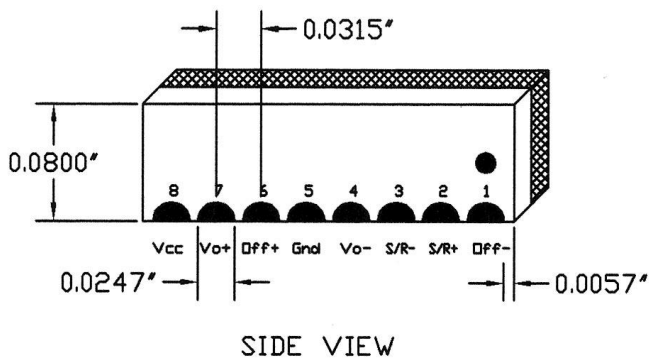

HMC1051/HMC1052/HMC1053

PACKAGE DRAWING HMC1052L (16-PIN LCC)

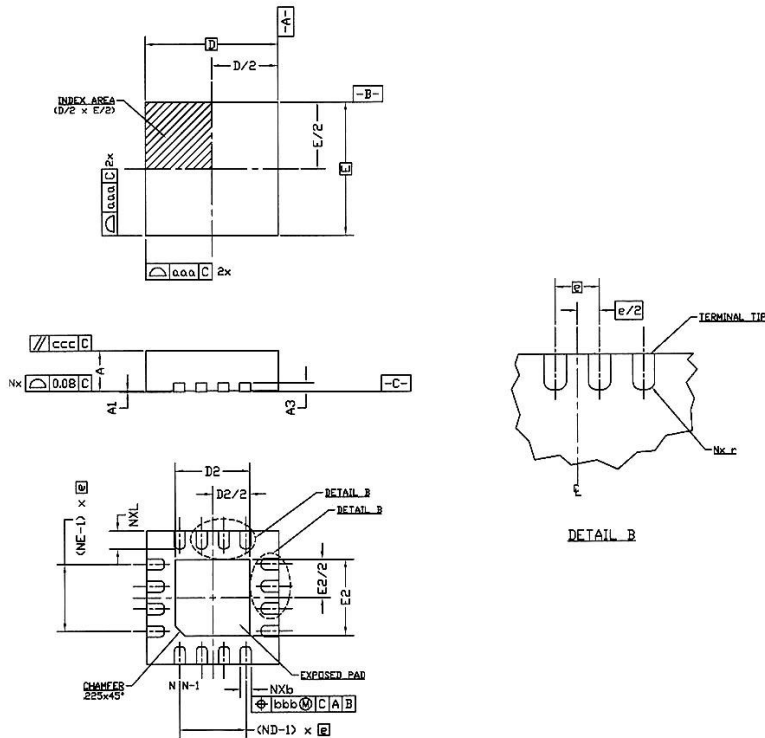

Symbol	Millimeters	
	min	max
A	0.80	1.00
A1	0	0.05
A3	0.20 REF	
b	0.18	0.30
D	3.00 BSC	
D2	1.55	1.80
E	3.00 BSC	
E2	1.55	1.80
e	0.50 BSC	
L	0.30	0.50
N	16	
ND	4	
NE	4	
r	B(min)/2	
aaa	0.15	
bbb	0.10	
ccc	0.10	

PACKAGE DRAWING HMC1053 (16-PIN LCC)

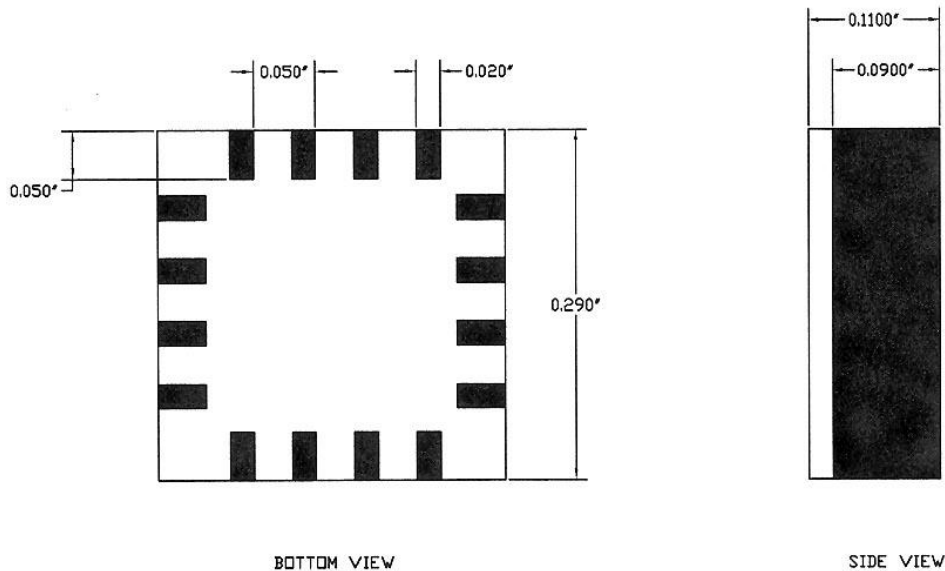

STENCIL DESIGN AND SOLDER PASTE

A 4 mil stencil and 100% paste coverage is recommended for the electrical contact pads.

REFLOW AND REWORK

The HMC1051ZL and HMC1053 parts should reference application note AN-216. The other part types have no special profile required and compatible with lead eutectic and lead-free solder paste reflow profiles up to 220°C. Honeywell recommends the adherence to solder paste manufacturer's guidelines. The HMC105X parts may be reworked with

HMC1051/HMC1052/HMC1053

soldering irons, but extreme care must be taken not to overheat the copper pads from the part's fiberglass substrate. Irons with a tip temperature no greater than 315°C should be used. Excessive rework risks the copper pads pulling away into the molten solder.

DEVICE OPERATION

The Honeywell HMC105X family of magnetoresistive sensors are Wheatstone bridge devices to measure magnetic fields. With power supply applied to a bridge, the sensor converts any incident magnetic field in the sensitive axis direction to a differential voltage output. In addition to the bridge circuit, the sensor has two on-chip magnetically coupled straps; the offset strap and the set/reset strap. These straps are Honeywell patented features for incident field adjustment and magnetic domain alignment; and eliminate the need for external coils positioned around the sensors.

The magnetoresistive sensors are made of a nickel-iron (Permalloy) thin-film deposited on a silicon wafer and patterned as a resistive strip element. In the presence of a magnetic field, a change in the bridge resistive elements causes a corresponding change in voltage across the bridge outputs.

These resistive elements are aligned together to have a common sensitive axis (indicated by arrows on the pinouts) that will provide positive voltage change with magnetic fields increasing in the sensitive direction. Because the output only is in proportion to the one-dimensional axis (the principle of anisotropy) and its magnitude, additional sensor bridges placed at orthogonal directions permit accurate measurement of arbitrary field direction. The combination of sensor bridges in two and three orthogonal axis permit applications such as compassing and magnetometry.

The offset strap allows for several modes of operation when a direct current is driven through it. These modes are: 1) Subtraction (bucking) of an unwanted external magnetic field, 2) null-ing of the bridge offset voltage, 3) Closed loop field cancellation, and 4) Auto-calibration of bridge gain.

The set/reset strap can be pulsed with high currents for the following benefits: 1) Enable the sensor to perform high sensitivity measurements, 2) Flip the polarity of the bridge output voltage, and 3) Periodically used to improve linearity, lower cross-axis effects, and temperature effects.

NOISE CHARACTERISTICS

The noise density for the HMR105X series is around 50nV/sqrt Hz at the 1 Hz corner, and quickly drops below 10nV/sqrt Hz at 5Hz and begins to fit the Johnson Noise value at just below 5nV/sqrt Hz beyond 50Hz. The 10Hz noise voltage averages around 1.4 micro-volts with a 0.8 micro-volts standard deviation.

CROSS-AXIS EFFECT

Cross-Axis effect for the HMR105X series is typically specified at $\pm 3\%$ of full scale to 1 gauss. See application note AN215 regarding this effect and methods for nulling.

OFFSET STRAP

The offset strap is a spiral of metalization that couples in the sensor element's sensitive axis. In two-axis designs, the strap is common to both bridges and must be multiplexed if each bridge requires a different strap current. In three-axis designs, the A and B bridges are together with the C bridge sharing a common node for series driving all three bridges' offset straps. Each offset strap measures nominally 15 ohms, and requires 10mA for each gauss of induced field. The straps will easily handle currents to buck or boost fields through the ± 6 gauss linear measurement range, but designers should note the extreme thermal heating on the die when doing so.

With most applications, the offset strap is not utilized and can be ignored. Designers can leave one or both strap connections (Off- and Off+) open circuited, or ground one connection node. Do not tie both strap connections together to avoid shorted turn magnetic circuits.

SET/RESET STRAP

The set/reset strap is another spiral of metalization that couples to the sensor elements easy axis (perpendicular to the sensitive axis on the sensor die). Like the offset strap, the set/reset strap runs through a pair of bridge elements to keep the overall die size compact. Each set/reset strap has a nominal resistance of 3 to 6 ohms with a minimum required peak

HMC1051/HMC1052/HMC1053

current of 400mA for reset or set pulses. With rare exception, the set/reset strap must be used to periodically condition the magnetic domains of the magneto-resistive elements for best and reliable performance.

A set pulse is defined as a positive pulse current entering the S/R+ strap connection. The successful result would be the magnetic domains aligned in a forward easy-axis direction so that the sensor bridge's polarity is a positive slope with positive fields on the sensitive axis result in positive voltages across the bridge output connections.

A reset pulse is defined as a negative pulse current entering the S/R+ strap connection. The successful result would be the magnetic domains aligned in a reverse easy-axis direction so that sensor bridge's polarity is a negative slope with positive fields on the sensitive axis result in negative voltages across the bridge output connections.

Typically a reset pulse is sent first, followed by a set pulse a few milliseconds later. By shoving the magnetic domains in completely opposite directions, any prior magnetic disturbances are likely to be completely erased by the duet of pulses. For simpler circuits with less critical requirements for noise and accuracy, a single polarity pulse circuit may be employed (all sets or all resets). With these uni-polar pulses, several pulses together become close in performance to a set/reset pulse circuit. Figure 1 shows a quick and dirty manual pulse circuit for uni-polar application of pulses to the set/reset strap.

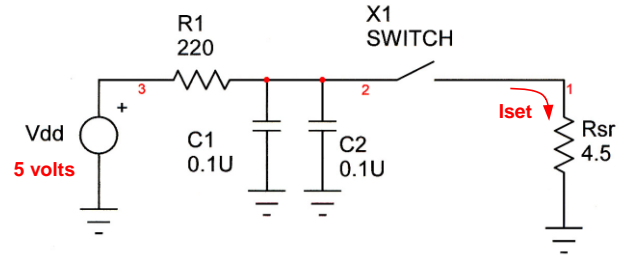

Figure 1
Set Pulse Circuit

APPLICATION NOTES

Low Cost 2-Axis Compass

Very high precision measurements can be made using the HMC105X family of sensors when interfaced with low noise amplifiers and 12 to 16-bit Analog-to-Digital (A/D) converters. For lower resolution (3° accuracy or more) or low cost compass applications, 8 or 10-bit A/D converters may be used with general purpose operational amplifiers. Figure 2 shows a typical 2-axis compassing application using readily available off-the-shelf components.

The basic principle of two-axis compassing is to orient the two sensor bridge elements horizontal to the ground (perpendicular to the gravitational field) and to measure the resulting X and Y analog output voltages. With the amplified sensor bridge voltages near-simultaneously converted (measured) to their digital equivalents, the arc-tangent Y/X can be computed to derive the heading information relative to the X-axis sensitive direction. See the application notes on compassing at Honeywell Magnetic Sensors website (www.magneticsensors.com) for basic principles and detailed application information.

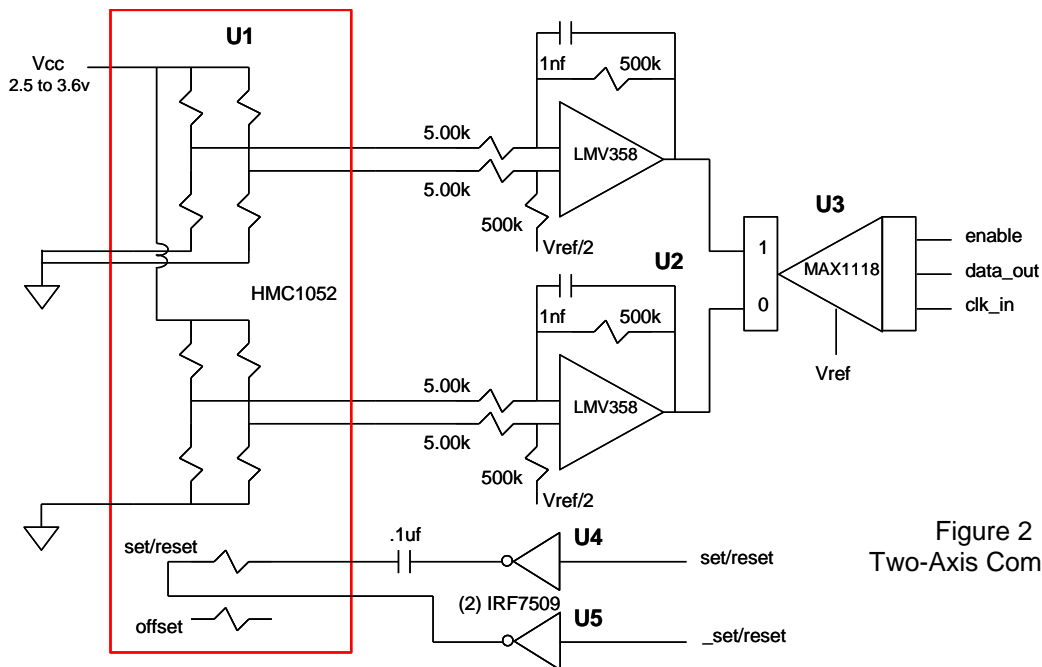

Figure 2
Two-Axis Compass

HMC1051/HMC1052/HMC1053

Set/Reset Circuit Notes

The above set/reset circuit in Figure 1 using the IRF7507 dual complementary MOSFETs is shown in detail by Figure 2 in its H-bridge driven configuration. This configuration is used primarily in battery operated applications where the 500mA nominal set/reset pulsed currents can be best obtained under low voltage conditions.

The 200-ohm resistor trickle charges the 1uF supply reservoir capacitor to the Vcc level, and isolates the battery from the high current action of the capacitors and MOSFET switches. Under conventional logic states one totem pole switch holds one node of the 0.1uF capacitor low, while the other switch charges Vcc into the capacitors opposite node. At the first logic change, the capacitor exhibits almost a twice Vcc flip of polarity, giving the series set/reset strap load plenty of pulse current. A restoring logic state flip uses the 0.1uF capacitors stored energy to create a second nearly equal but opposite polarity current pulse through the set/reset strap.

For operation at normal 3.3 or 5-volt logic levels, a single complementary MOSFET pair can be used in a single ended circuit shown in Figure 4. Other complementary MOSFET pairs can be used with the caution that the chosen devices should have less than 0.5 ohms ON resistance and be able to handle the needed supply voltages and set/reset currents. Note that even a 1Hz rate of set/reset function draws an average current of less than 2 microamperes.

Magnetic Field Detection

For simple magnetic field sensing applications such as Magnetic Anomaly Detectors (MADs) and Magnetometers, a similar circuit to the compass application can be implemented using one, two, or three magnetic sensors. In the example circuit in Figure 5, a HMC1051Z sensor bridge is used with a low voltage capable dual op-amp to detect sufficient intensity of a magnetic field in a single direction. Uses of the circuit include ferrous object detection such as vehicle detection, a “sniffer” for currents in nearby conductors, and magnetic proximity switching. By using two or three sensor circuits with HMC1051, HMC1052, or HMC1053 parts, a more omni-directional sensing pattern can be implemented. There is nothing special in choosing the resistors for the differential op-amp gain stages other than having like values (e.g. the two 5kΩ and the 500kΩ resistors) matched at 1% tolerance or better to reject common-mode interference signals (EMI, RFI). The ratio of the 500kΩ/5kΩ resistors sets the stage gain and can be optimized for a specific purpose. Typical gain ratios for compass and magnetometer circuits using the HMC105X family, range from 50 to 500. The choice of the 5kΩ value sets impedance loading seen by the sensor bridge network and should be about 4 kilo-ohms or higher for best voltage transfer or matching. Note that Figure 5 also shows an alternative set/reset strap driver circuit using two darlington complementary paired BJTs as electronic switches.

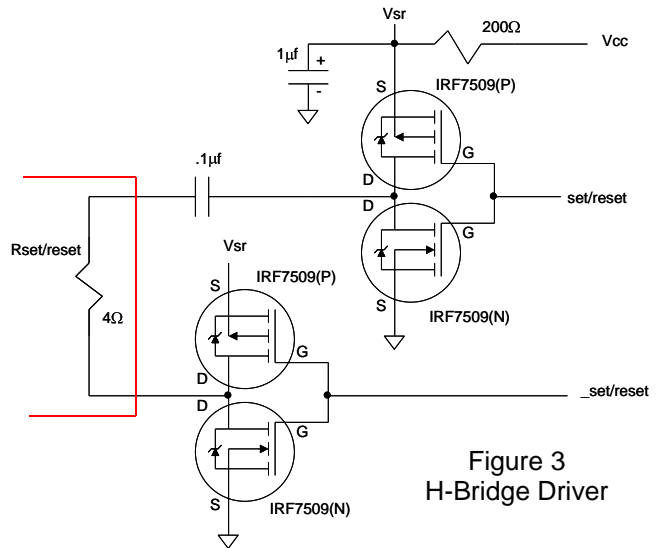

Figure 3
H-Bridge Driver

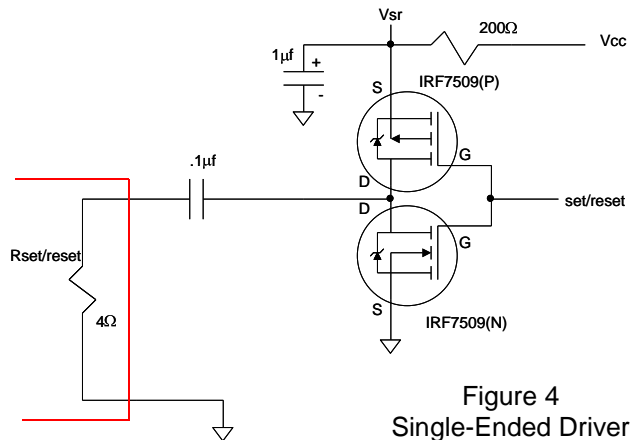

Figure 4
Single-Ended Driver

HMC1051/HMC1052/HMC1053

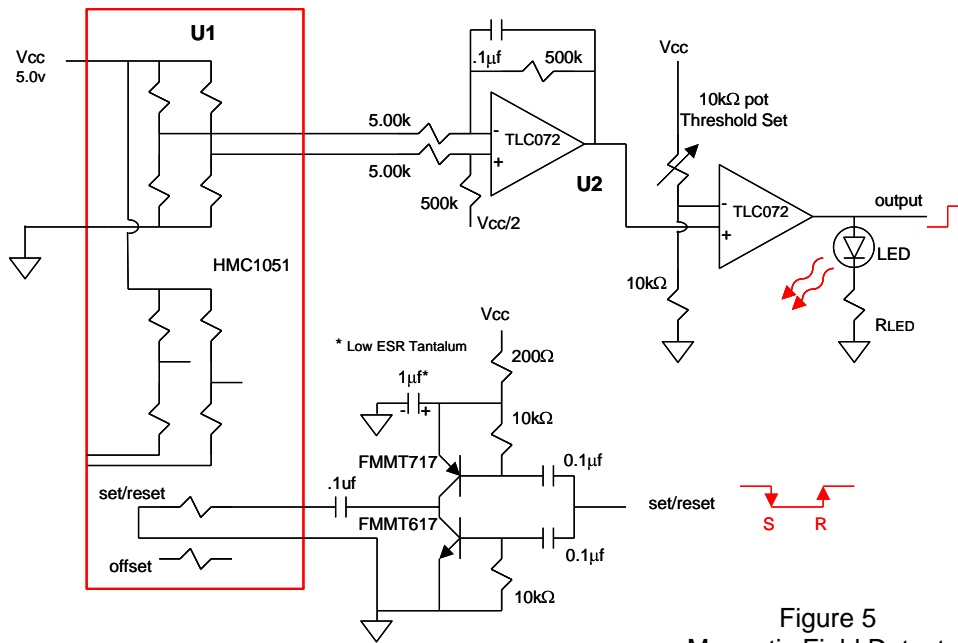

Figure 5
Magnetic Field Detector

Alternating or Direct Current Sensing

The HMC105X family sensors can be utilized in a novel way for moderate to high current sensing applications using a nearby external conductor providing the sensed magnetic field to the bridge. Figure 6 shows a HMC1051Z used as a current sensor with thermistor element performing a temperature compensation function for greater accuracy over a wide range of operational temperatures. Selection of the temperature compensation (tempco) resistors used depends on the thermistor chosen and is dependant on the thermistor's %/°C shift of resistance. For best op-amp compatibility, the thermistor resistance should be above about 1000 ohms. The use of a 9-volt alkaline battery supply is not critical to this application, but permits fairly common operational amplifiers such as the 4558 types to be used. Note that the circuit must be calibrated based on the final displacement of the sensed conductor to the measuring bridge. Typically, an optimally oriented measurement conductor can be placed about one centimeter away from the bridge and have reasonable capability of measuring from tens of milliamperes to beyond 20 amperes of alternating or direct currents. See application note AN-209 for the basic principles of current sensing using AMR bridges.

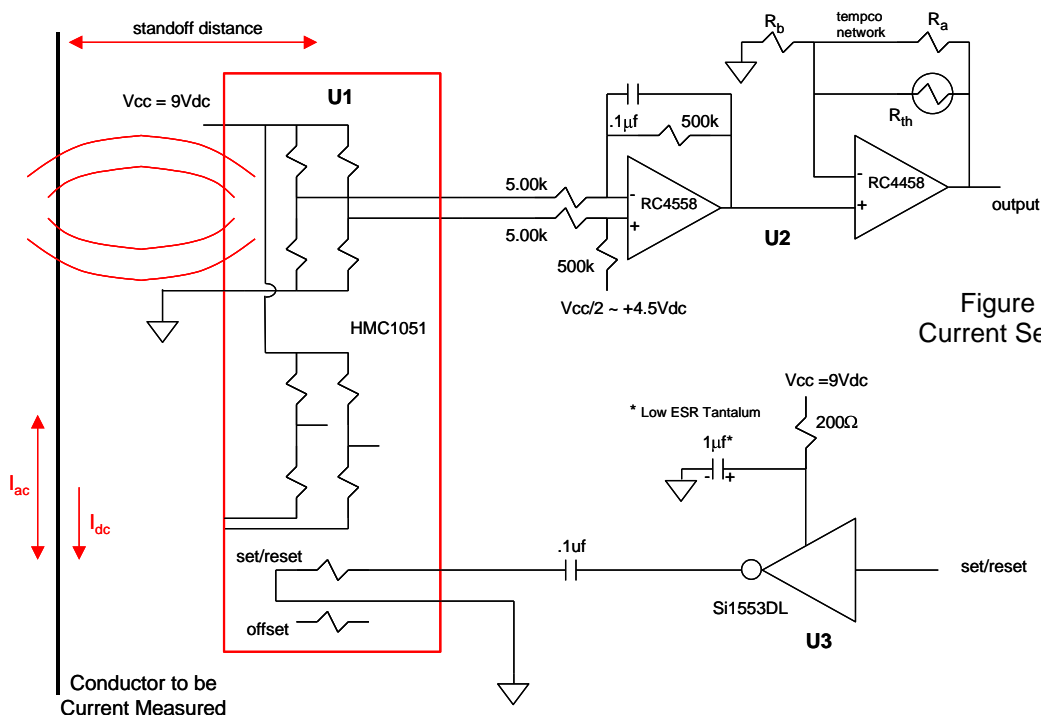

Figure 6
Current Sensor

HMC1051/HMC1052/HMC1053

Three Axis Compassing with Tilt Compensation

For full three-axis compassing, the circuit depicted in Figure 7 shows both a HMC1051 and a HMC1052 used for sensing the magnetic field in three axes. Alternatively a single HMC1053 could be used for a single sensor package design. A two-axis accelerometer with digital (PWM) outputs is also shown to provide pitch and roll (tilt) sensing, to correct the three-axis magnetic sensors outputs into the tilt-compensated two-axis heading. The accelerometer can be substituted with a fluidic 2-axis tilt sensor if desired. For lower voltage operation with Lithium battery supplies (2.5 to 3.6Vdc), the Set/Reset circuit should be upgraded from a single IRF7507 to the dual IRF7507 implementation (per Figure 2) to permit a minimum 1-ampere pulse (500mA per set/reset strap resistance) to both the HMC1052 and HMC1051 sensors.

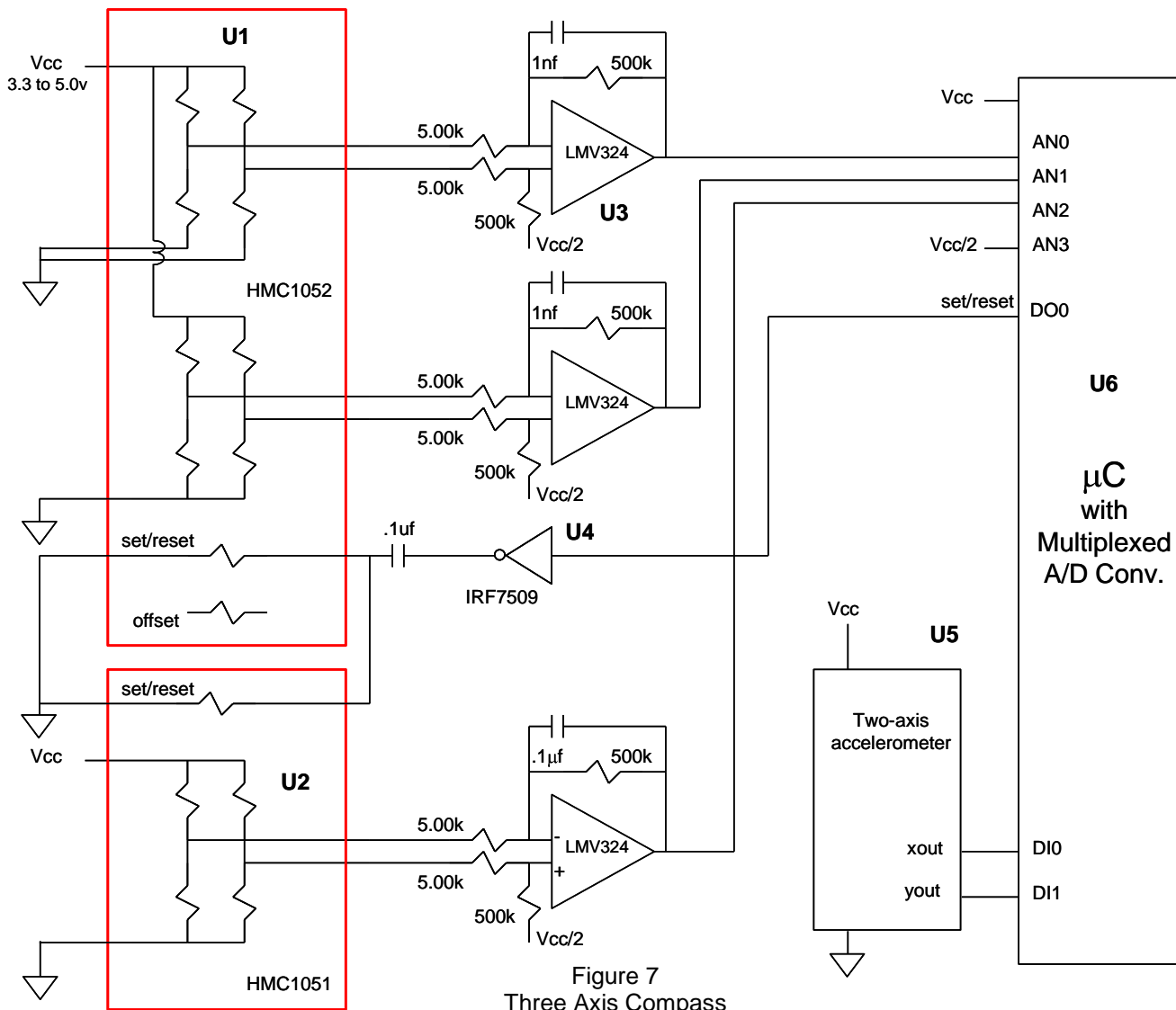
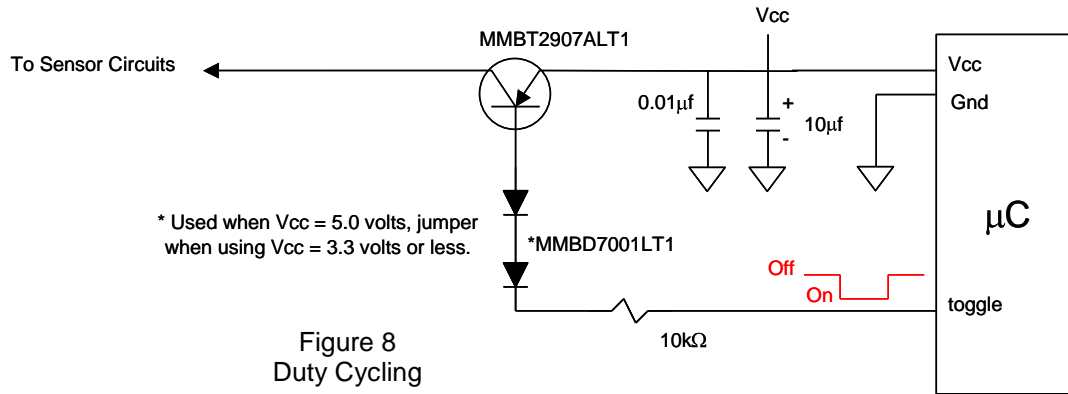

Figure 7
Three Axis Compass

Duty Cycling for Lower Energy Consumption

For battery powered and other applications needing limited energy consumption, the sensor bridge and support electronics can be switched “off” between magnetic field measurements. The HMC105X family of magnetic sensors are very low capacitance (Bandwidth > 5MHz) sensor bridges and can stabilize quickly, typically before the support electronics can. Other energy saving ideas would be to minimize the quantity of set/reset pulses which saves energy over the battery life. Figure 8 shows a simple supply switching circuit that can be microprocessor controlled to duty cycle (toggle) the electronics in moderate current (<25mA) applications.

HMC1051/HMC1052/HMC1053



ORDERING INFORMATION

Part Number	Package Style
HMC1051Z	One Axis Magnetic Sensor – SIP8
HMC1051ZL	One Axis Magnetic Sensor – 8-PIN IN-LINE LCC
HMC1052L HMC1052L-TR	Two Axis Magnetic Sensors – 16-PIN LCC 3,000 units/reel
HMC1053	Three Axis Magnetic Sensors – 16-PIN LCC

FIND OUT MORE

For more information on Honeywell's Magnetic Sensors visit us online at www.magneticsensors.com or contact us at 800-323-8295 (763-954-2474 internationally).

The application circuits herein constitute typical usage and interface of Honeywell product. Honeywell does not warranty or assume liability of customer-designed circuits derived from this description or depiction.

Honeywell reserves the right to make changes to improve reliability, function or design. Honeywell does not assume any liability arising out of the application or use of any product or circuit described herein; neither does it convey any license under its patent rights nor the rights of others.

U.S. Patents 4,441,072, 4,533,872, 4,569,742, 4,681,812, 4,847,584 and 6,529,114 apply to the technology described

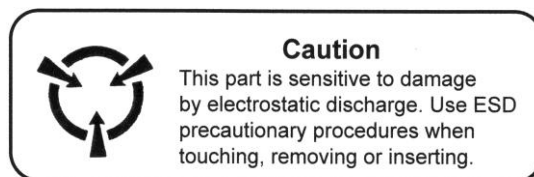

CAUTION: ESDS CAT. 1B