

**Compact, intelligent sensors featuring MEMS precision technology for repeatable airflow detection**

- RoHS / Lead-free and lead solder compatible
- Precision uni-directional air velocity detection
- Integral passive Dust Segregation System (DSS)
- Compact size: 39 (L) x 20 (W) x 9 (H) mm
- User friendly – no adjustment necessary
- Fast-fit feature for large quantity installation



### Application Examples

- Cassette (ceiling / suspended), multi-modular air conditioners
- Duct connected heating and air conditioning systems
- Alternative for single point Pitot tube
- Alternative for thermal dispersion measurement
- Air & water cooled chillers, indoor packaged AC systems
- Window / split, multi-split residential AC coolers
- Air purifiers, dehumidifiers
- Fan assisted space heaters
- Air cooled, high power indoor lighting
- Mission critical PC, Workstation ventilation
- 19" rack / tray mounted PSU watchdog ventilation systems

### Ordering Information

Model	Case	Applicable Gas	Flow Range	Notes
D6F-W01A1	PPS (Polyphenylene Sulphide)	Air	0 – 1 m/sec	Built-in orifice
D6F-W04A1	PPS (Polyphenylene Sulphide)	Air	0 – 4 m/sec	Built-in orifice
D6F-W CABLE				Optional (recommended)

### ■ Rating

Absolute maximum rating

Item	Term	Ratings	Unit
Power-supply voltage	V <sub>CC</sub>	26.4	VDC
Output voltage	V <sub>OUT</sub>	6	VDC

## ■ Electrical Performance

Recommended operation condition and DC characteristic

Item	Term	Condition	MIN	TYP	MAX	Unit
Power-supply voltage	V <sub>CC</sub>	–	10.8	–	26.4	VDC
Operating temperature	T <sub>OPR</sub>	–	-10	–	60	°C
Maximum output voltage	V <sub>OH</sub>	V <sub>CC</sub> = 12VDC TO 24VDC I <sub>OH</sub> = 0.5mA	5	–	5.7	VDC
Minimum output voltage	V <sub>OL</sub>	V <sub>CC</sub> = 12VDC TO 24VDC I <sub>OL</sub> = -0.5mA	0	–	1	VDC

## ■ Basic Performance

The flow velocity at 25°C, 1 atmosphere

### Operating Characteristics

D6F-01A1

Flow Velocity (m/s)	0	0.25	0.50	0.75	1.00
Output Voltage (V)	1.00 ±0.2	1.35 ±0.2	2.01 ±0.2	3.27 ±0.2	5.00 ±0.2

D6F-04A1

Flow Velocity (m/s)	0	1.00	2.00	3.00	4.00
Output Voltage (V)	1.00 ±0.2	1.58 ±0.2	2.88 ±0.2	4.11 ±0.2	5.00 ±0.2

Note: 1. Measurement condition: Power-supply voltage 12VDC, ambient temperature 25°C and dry air.

2. Air velocity. D6F-W is optimally adjusted for air velocity detection, derived from mass air-flow measurement according to our in-house test method using a wind tunnel phi48mm

## ■ Characteristics

Degree of Protection	IP40
Applicable Gas	Air
Electrical Connection	Connector (3 wire)
Output Signal	Analogue, 1-5VDC (load resistance 10kohm min)
Current Consumption	Max 15mA (no load, V <sub>CC</sub> = 12 to 24VDC, V <sub>SS</sub> = GND = 0V, 25°C)
Repeat Accuracy	+/- 5% FSD max, 25°C
Insulation Resistance	20Mohm min. (500VDC between lead terminals and case)
Dielectric Strength	500VAC, 50/60Hz for 1 minute (leakage current typ. <1mA) between lead terminals
Withstand Pressure	Not applicable
Operating Temperature	-10 to +60°C (with no ice or dew condensation)
Operating Humidity	85%RH max. (with no ice or dew condensation)
Storage Temperature	-40 to +80°C (with no ice or dew condensation)
Storage Humidity	85%RH max. (with no ice or dew condensation)

## ■ Precautions

1. Avoid use in excessively dirty, wet environments
2. Do not use in the presence of flammable gases (e.g. hydrogen, methane, ethane and liquefied petroleum gas. In addition, do not use with corrosive gases (eg chlorine, sulphur, acids, alkalis etc).
3. Install in the direction of the arrow indicated.
4. For best results (optimum accuracy), mount horizontally.
5. Use one or two M3 screws for mounting. Do not exceed a fixing torque of 0.59Nm
6. Fast-fit for high quality installation is possible by using one M3 screw in conjunction with a suitable mount locating pin either in the other M3 fixing hole or using the small moulded hole located underneath.
7. Do not modify D6F-W in any way.
8. Do not place any object in or close to the inlet and outlet orifices
9. Do not use the sensor in any of the following environments:-
  - a location that receives radiant heat from the sun or apparatus
  - a place where intense light may radiate down
  - places where corrosive gas, especially sulphur and ammonia gases are present
  - where fast changing temperatures occur
  - locations prone to freezing, high humidity, condensation
  - places where large magnitudes of vibration or shock could occur
10. Noise countermeasures: VERY IMPORTANT: Take suitable precautions to minimise the effects and potential for induced electrical noise. Install away from apparatus that generates strong high frequencies, surges and spikes. Take particular care to install away from AC power transformers, live mains power lines and high power magnetic circuits. Attach a surge suppressor and a noise filter to the peripheral equipment.
11. Ensure good grounding is achieved by grounding the GND terminal to the peripheral equipments main ground frame connection and its associated regulated power supply.
12. Do not make a direct solder connection to the integral terminals. It is recommended you use the optional cable "D6F-W Cable" for attachment and to ensure correct connection.
13. D6F-W is a precision component. Keep in original packaging and remove only when ready for installation. Damage may occur if subjected to excessive force (e.g. dropped or kicked). Any item suspected to be damaged should be discarded.
14. Immediately following installation, a qualified person should perform checks to ensure safe, satisfactory operation.

## Dimensions

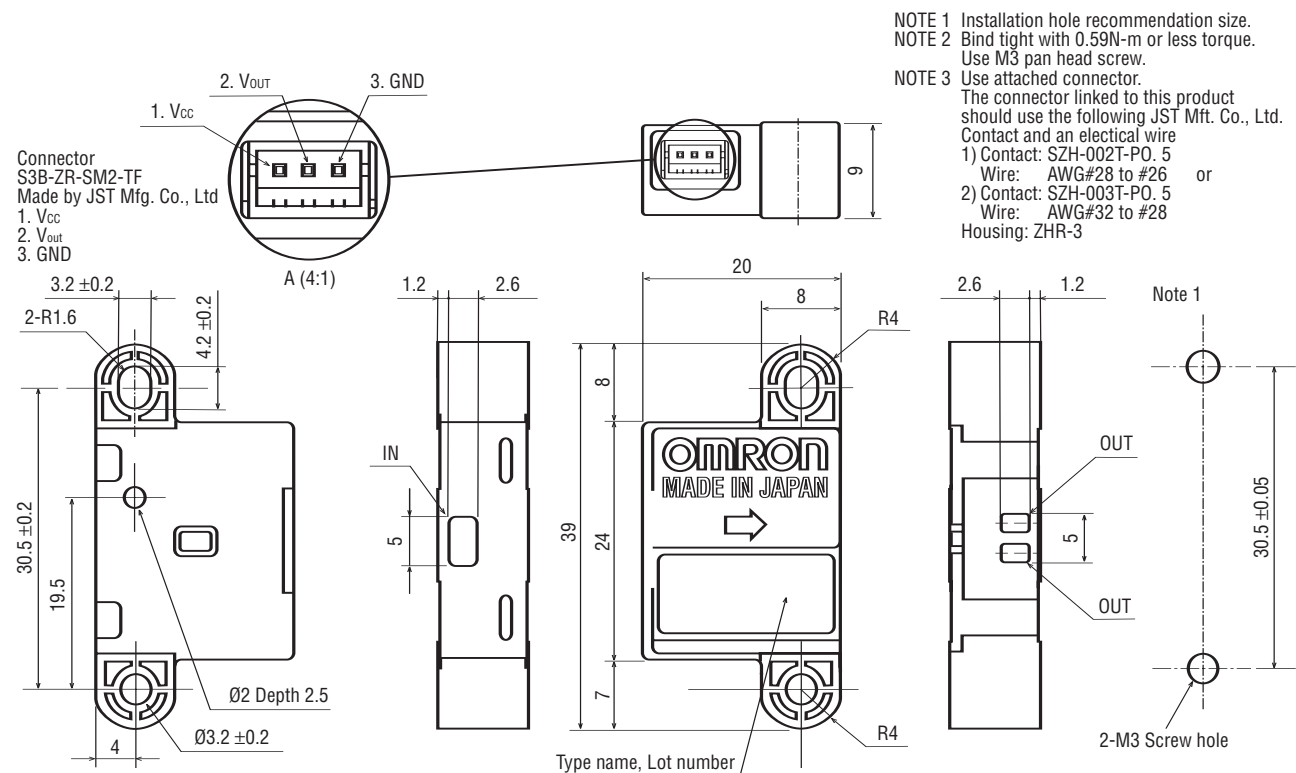

## ■ D6F-W Cable

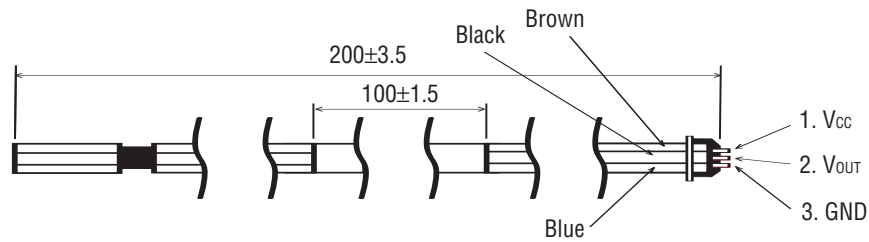

## ■ Packaging

No.	Qty	Name	Material
1	5	Pad	Coated board paper
2	4	Tray	Polyethylene
3	1	Box	Coated board paper
4	1	Label/Bar Code	-

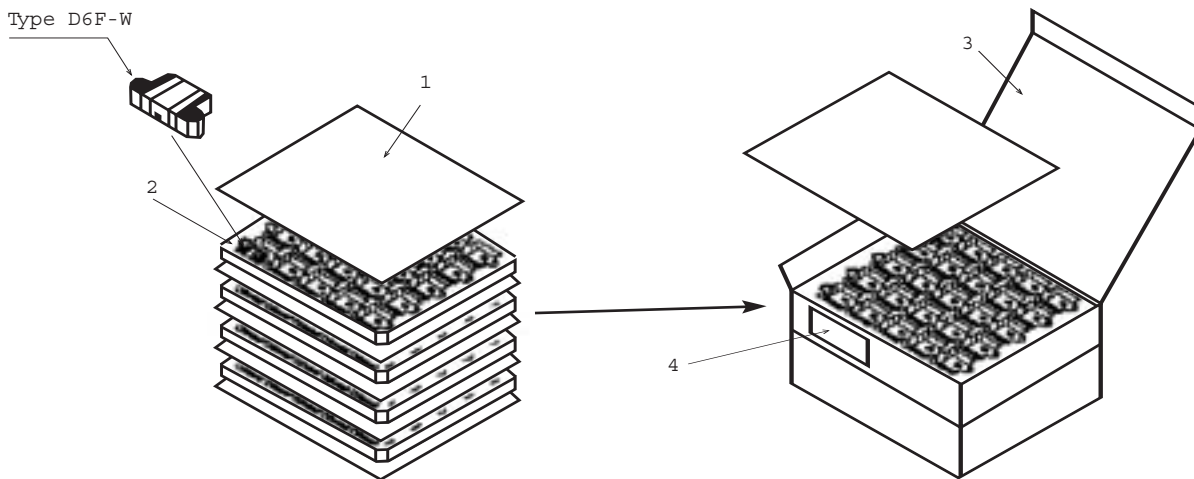

## ■ Warranty

Omron corporation manufactures products to the highest standards and warrants that all products it manufactures are free of defects and faulty workmanship.

Please contact your local Omron representative for warranty information.

Specifications subject to change without notice. Any information supplied is believed to be accurate and reliable at the time of printing.

We provide application assistance personally and through our literature including our website for guidance only. It is the customers full responsibility to determine suitability of product in any intended application.

**ALL DIMENSIONS SHOWN ARE IN MILLIMETERS.**

To convert millimeters into inches, multiply by 0.03937. To convert grams into ounces, multiply by 0.03527.

Cat. No. D6F-W01A/04A1

In the interest of product improvement, specifications are subject to change without notice.

# OMRON

## Omron Electronic Components Europe BV

Wegalaan 57  
2132 JD Hoofddorp  
The Netherlands  
Tel: +31 23 568 1200  
Fax: +31 23 568 1212