

DABiC-5 Latched Sink Drivers

Last Time Buy

This part is in production but has been determined to be LAST TIME BUY. This classification indicates that the product is obsolete and notice has been given. Sale of this device is currently restricted to existing customer applications. The device should not be purchased for new design applications because of obsolescence in the near future. Samples are no longer available.

Date of status change: May 3, 2010

Deadline for receipt of LAST TIME BUY orders: October 29, 2010

Recommended Substitutions:

For existing customer transition, and for new customers or new applications, refer to your Allegro sales representative.

NOTE: For detailed information on purchasing options, contact your local Allegro field applications engineer or sales representative.

Allegro MicroSystems, Inc. reserves the right to make, from time to time, revisions to the anticipated product life cycle plan for a product to accommodate changes in production capabilities, alternative product availabilities, or market demand. The information included herein is believed to be accurate and reliable. However, Allegro MicroSystems, Inc. assumes no responsibility for its use; nor for any infringements of patents or other rights of third parties which may result from its use.

DABiC-5 Latched Sink Drivers

Features and Benefits

- 3.3 to 5 V logic supply range
- Up to 10 MHz data input rate
- High-voltage, high-current outputs
- Darlington current-sink outputs, with improved low-saturation voltages
- CMOS, TTL compatible inputs
- Output transient protection
- Internal pull-down resistors
- Low-power CMOS latches

Packages

A6800
14-pin SOICN
(L package)



A6801
28-pin PLCC
(EP package)

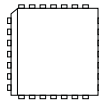

Description

The A6800 and A6801 latched-input BiMOS ICs merge high-current, high-voltage outputs with CMOS logic. The CMOS input section consists of 4 or 8 data (D type) latches with associated common CLEAR, STROBE, and OUTPUT ENABLE circuitry. The power outputs are bipolar NPN Darlington. This merged technology provides versatile, flexible interface. These BiMOS power interface ICs greatly benefit the simplification of computer or microprocessor I/O. The A6800 ICs each contain four latched drivers. A6801 ICs contain eight latched drivers.

The CMOS inputs are compatible with standard CMOS circuits. TTL circuits may mandate the addition of input pull-up resistors. The bipolar Darlington outputs are suitable for directly driving many peripheral/power loads: relays, lamps, solenoids, small DC motors, and so forth.

All devices have open-collector outputs and integral diodes for inductive load transient suppression. The output transistors are capable of sinking 600 mA and can withstand at least 50 V in the off state. Because of limitations on package power dissipation, the simultaneous operation of all drivers at maximum rated current can only be accomplished by a reduction in duty cycle. Outputs may be paralleled for higher load current capability.

Continued on the next page...

Approximate scale 1:1

Functional Block Diagram

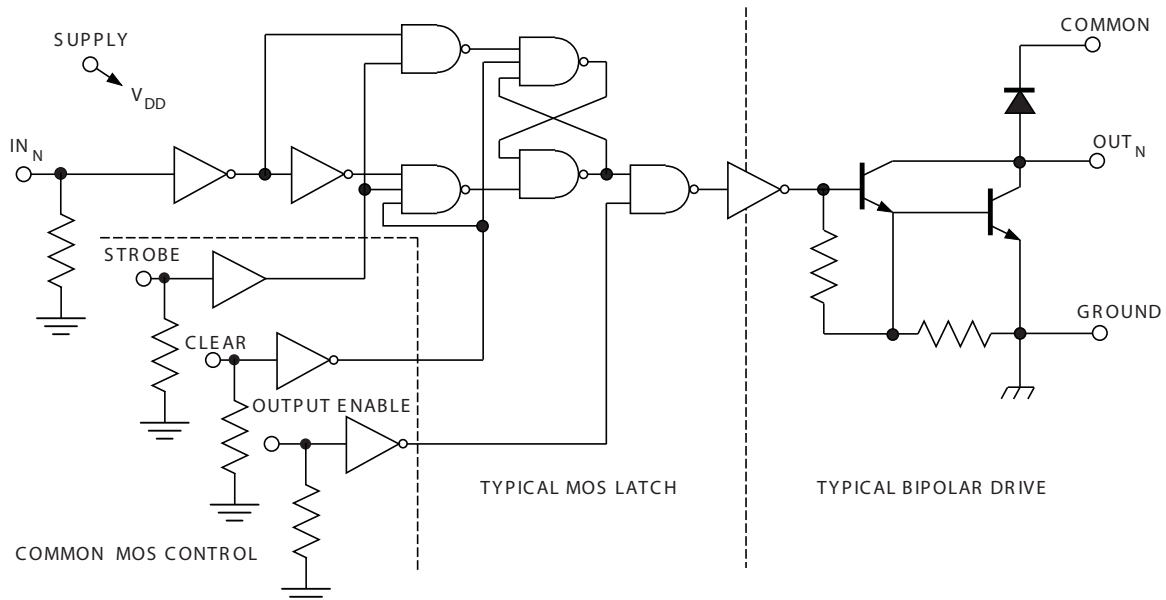

A6800 and A6801

DABiC-5 Latched Sink Drivers

Description (continued)

The A6800SL is furnished in a surface-mountable SOIC, and the A6801SEP in a 28-lead PLCC. These devices are lead (Pb) free, with 100% matte tin plated leadframes.

Applications include:

- Relays
- Lamps
- Solenoids
- Small DC motors

Selection Guide

Part Number	Package	Packing
A6800SLTR-T	14-pin SOIC	2500 per reel
A6801SEPTR-T	28-pin PLCC	800 per reel

Absolute Maximum Ratings*

Characteristic	Symbol	Notes	Rating	Units
Output Voltage	V_{CE}		50	V
Supply Voltage	V_{DD}		7	V
Input Voltage Range	V_{IN}		-0.3 to $V_{DD} + 0.3$	V
Continuous Collector Current	I_C		600	mA
Operating Ambient Temperature	T_A	Range S	-20 to 85	°C
Maximum Junction Temperature	$T_J(\max)$		150	°C
Storage Temperature	T_{stg}		-55 to 150	°C

*Caution: CMOS devices have input-static protection, but are susceptible to damage when exposed to extremely high static-electrical charges.

Allowable Power Dissipation

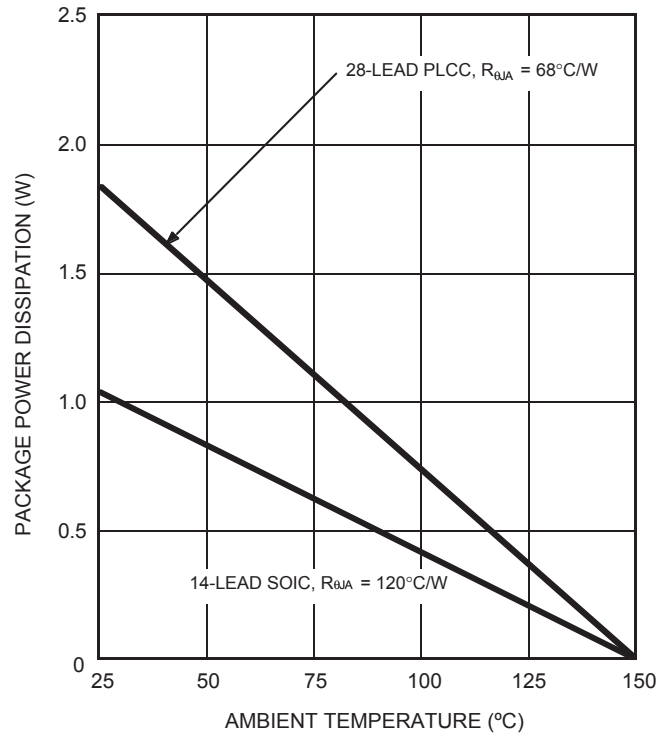

Typical Input Circuit

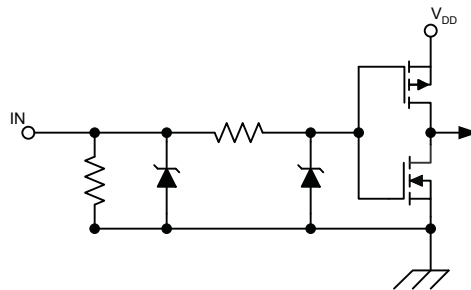

ELECTRICAL CHARACTERISTICS¹ Unless otherwise noted: $T_A = 25^\circ\text{C}$, logic supply operating voltage $V_{DD} = 3.0$ to 5.5V

Characteristic	Symbol	Test Conditions	$V_{DD} = 3.3\text{V}$			$V_{DD} = 5\text{V}$			Units
			Min.	Typ.	Max.	Min.	Typ.	Max.	
Output Leakage Current	I_{CEX}	$V_{OUT} = 50\text{V}$	–	–	10	–	–	10	μA
Output Sustaining Voltage	$V_{CE(SUS)}$	$I_{OUT} = 350\text{mA}$, $L = 3\text{mH}$	35	–	–	35	–	–	V
Collector-Emitter Saturation Voltage	$V_{CE(SAT)}$	$I_{OUT} = 100\text{mA}$	–	0.8	1.0	–	0.8	1.0	V
		$I_{OUT} = 200\text{mA}$	–	0.9	1.1	–	0.9	1.1	V
		$I_{OUT} = 350\text{mA}$ (See note 2)	–	1.0	1.3	–	1.0	1.3	V
Input Voltage	$V_{IN(1)}$		2.2	–	–	3.3	–	–	V
	$V_{IN(0)}$		–	–	1.1	–	–	1.7	V
Input Resistance	R_{IN}		50	–	–	50	–	–	$\text{k}\Omega$
Logic Supply Current	$I_{DD(1)}$	One output on, $I_{OUT} = 100\text{mA}$	–	–	1.0	–	–	1.0	mA
	$I_{DD(0)}$	All outputs off	–	130	150	–	130	150	μA
Clamp Diode Leakage Current	I_r	$V_r = 50\text{V}$	–	–	50	–	–	50	μA
Clamp Diode Forward Voltage	V_f	$I_f = 350\text{mA}$	–	–	2.0	–	–	2.0	V
Output Fall Time	t_f	$V_{CC} = 50\text{V}$, $R_1 = 500\Omega$, $C_1 \leq 30\text{pF}$	–	80	–	–	80	–	ns
Output Rise Time	t_r	$V_{CC} = 50\text{V}$, $R_1 = 500\Omega$, $C_1 \leq 30\text{pF}$	–	100	–	–	100	–	ns

¹Operation of these devices with standard TTL or DTL may require the use of appropriate pull-up resistors to ensure a minimum logic 1.

²Because of limitations on package power dissipation, the simultaneous operation of multiple drivers can only be accomplished by reduction in duty cycle.

Truth Table

IN_N	STROBE	CLEAR	OUTPUT ENABLE	OUT_N	
				t-1	t
0	1	0	0	X	OFF
1	1	0	0	X	ON
X	X	1	X	X	OFF
X	X	X	1	X	OFF
X	0	0	0	ON	ON
X	0	0	0	OFF	OFF

X = irrelevant

t-1 = previous output state

t = present output state

Timing Requirements and Specifications
(Logic Levels are V_{DD} and Ground)

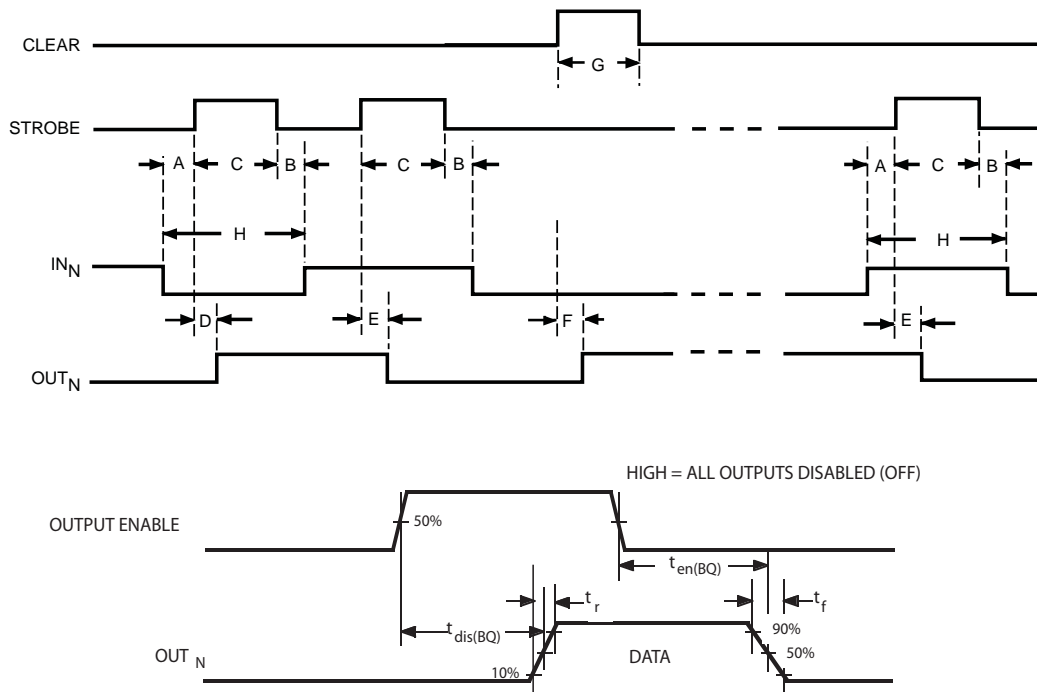

Key	Description	Time (ns)
A	Minimum data active time before Strobe enabled (Data Set-Up Time)	25
B	Minimum data active time after Strobe disabled (Data Hold Time)	25
C	Minimum Strobe pulse width	50
D	Maximum time between Strobe activation and transition from output on to output off*	500
E	Maximum time between Strobe activation and transition from output off to output on*	500
F	Maximum time between Clear activation and transition from output on to output off*	500
G	Minimum Clear pulse width	50
H	Minimum data pulse width	100
$t_{dis(BQ)}$	Output Enable to output off delay*	500
$t_{en(BQ)}$	Output Enable to output on delay*	500

*Conditions for output transition testing are: $V_{CC} = 5\text{ V}$, $V_{DD} = 5\text{ V}$, $R_1 = 500\ \Omega$, $C_1 \leq 30\text{ pF}$.

NOTE: Information present at an input is transferred to its latch when the STROBE is high. A high CLEAR input will set all latches to the output off condition regardless of the data or STROBE input levels. A high

OUTPUT ENABLE will set all outputs to the off condition, regardless of any other input conditions. When the OUTPUT ENABLE is low, the outputs depend on the state of their respective latches.

A6800 L Package

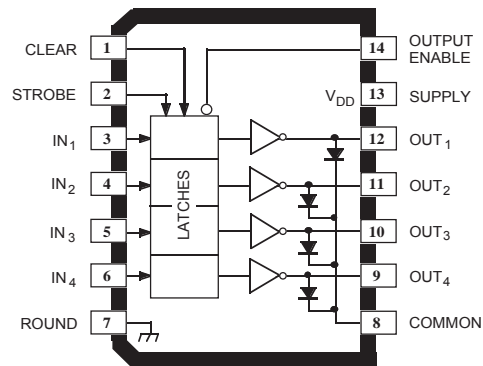

A6801 EP Package

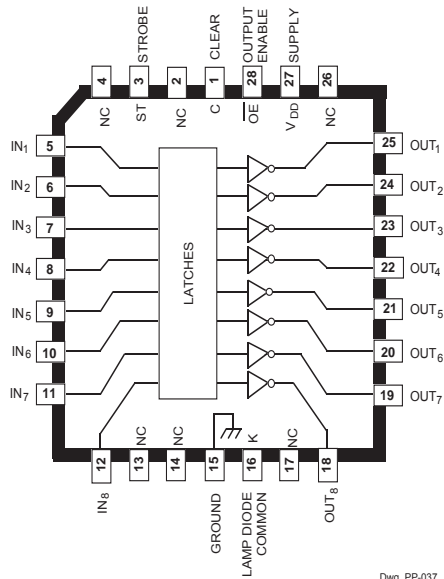

Dwg. PP-037

**TYPICAL APPLICATION
UNIPOLAR STEPPER-MOTOR DRIVE**

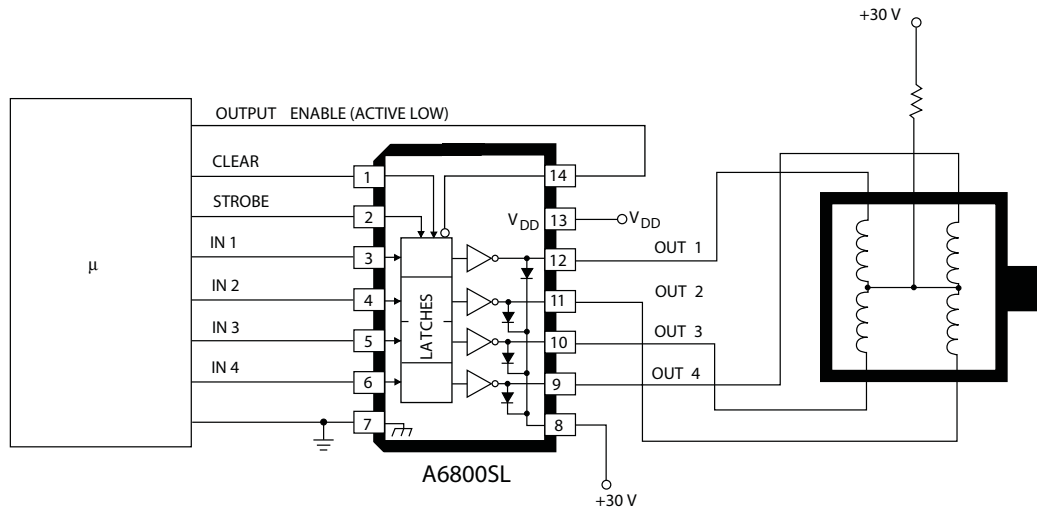

Dwg. No. B-1537

UNIPOLAR WAVE DRIVE

UNIPOLAR 2-PHASE DRIVE

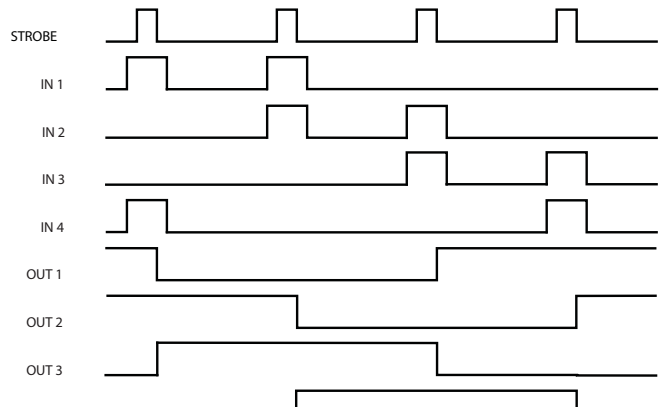
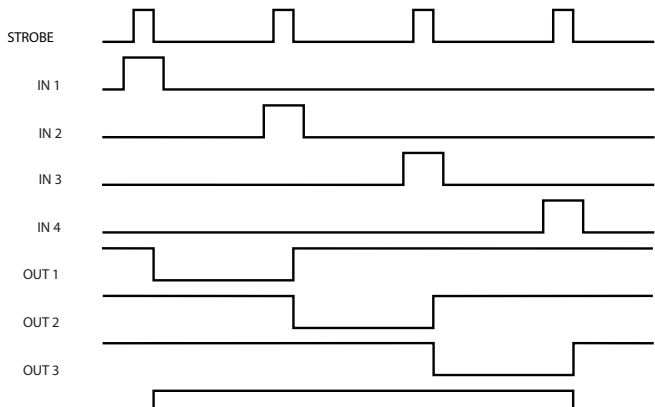

Package EP (A6801) 28-pin PLCC

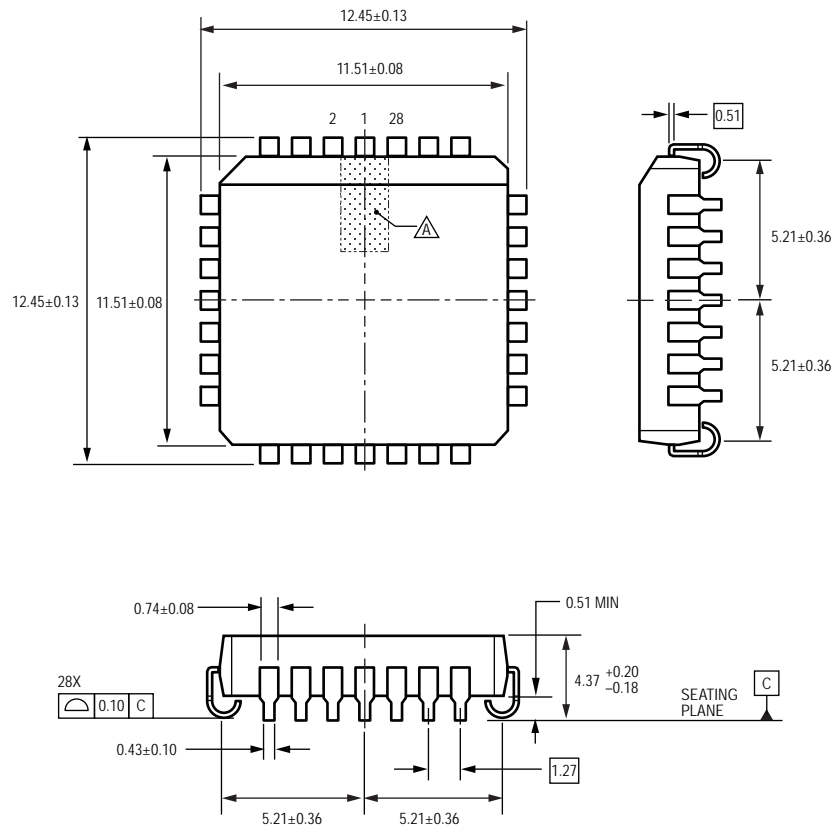

For Reference Only
 (reference JEDEC MS-018 AB)
 Dimensions in millimeters
 Dimensions exclusive of mold flash, gate burrs, and dambar protrusions
 Exact case and lead configuration at supplier discretion within limits shown
 ▲ Terminal #1 mark area

Package L (A6800) 14-pin SOICN

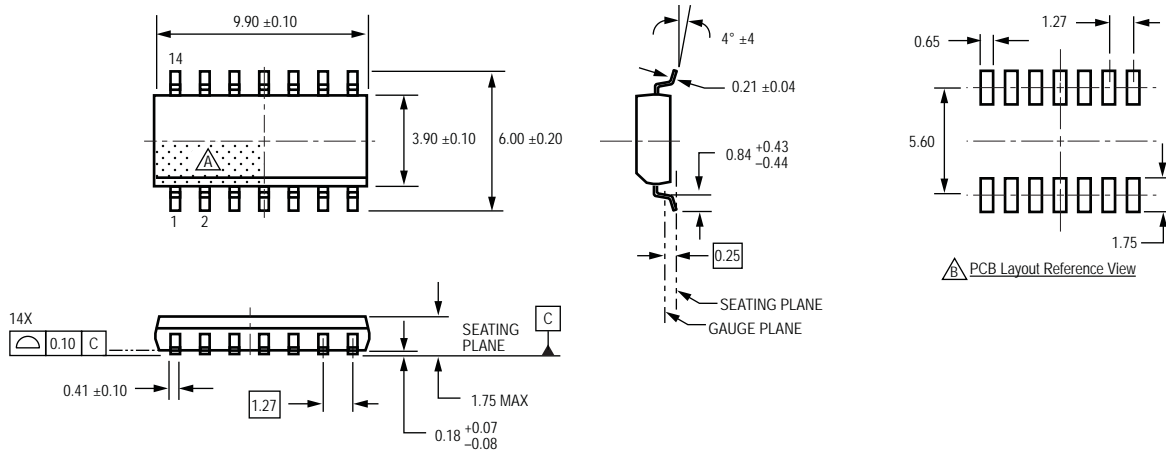

For Reference Only
Dimensions in millimeters
(reference JEDEC MS-012 AB)
Dimensions exclusive of mold flash, gate burrs, and dambar protrusions
Exact case and lead configuration at supplier discretion within limits shown

△ Terminal #1 mark area
△ Reference pad layout (reference IPC SOIC127P600X175-14M)
All pads a minimum of 0.20 mm from all adjacent pads; adjust as necessary to meet application process requirements and PCB layout tolerances

Copyright ©2003-2010, Allegro MicroSystems, Inc.

The products described here are manufactured under one or more U.S. patents or U.S. patents pending.

Allegro MicroSystems, Inc. reserves the right to make, from time to time, such departures from the detail specifications as may be required to permit improvements in the performance, reliability, or manufacturability of its products. Before placing an order, the user is cautioned to verify that the information being relied upon is current.

Allegro's products are not to be used in life support devices or systems, if a failure of an Allegro product can reasonably be expected to cause the failure of that life support device or system, or to affect the safety or effectiveness of that device or system.

The information included herein is believed to be accurate and reliable. However, Allegro MicroSystems, Inc. assumes no responsibility for its use; nor for any infringement of patents or other rights of third parties which may result from its use.

For the latest version of this document, visit our website:

www.allegromicro.com

