

Light-to-Digital Sensor

The ISL29001 is an integrated ambient light sensor with ADC and I²C interface. With a spectral sensitivity curve matched to that of the human eye, the ISL29001 provides 15-bit effective resolution while rejecting 50Hz and 60Hz flicker caused by artificial light sources.

In normal operation, the ISL29001 consumes less than 300µA of supply current. A software power-down mode controlled via the I²C interface disables all but the I²C interface. A power-down pin is also provided which reduces power consumption to less than 1µA.

The ISL29001 includes an internal oscillator which provides 100ms automatic integration periods, or can be externally timed by I²C commands. Both the internal timing and the illuminance resolution can be adjusted with an external resistor.

Designed to operate on supplies from 2.5V to 3.3V, the ISL29001 is specified for operation over the -40°C to +85°C ambient temperature range. It is packaged in a clear 6 Ld ODFN package.

Ordering Information

PART NUMBER	TAPE & REEL	PACKAGE	PKG. DWG. #
ISL29001IROZ (See Note)	-	6 Ld ODFN (Pb-Free)	MDP0052
ISL29001IROZ-T7 (See Note)	7"	6 Ld ODFN (Pb-Free)	MDP0052

NOTE: Intersil Pb-free products employ special Pb-free material sets; molding compounds/die attach materials and 100% matte tin plate termination finish, which are RoHS compliant and compatible with both SnPb and Pb-free soldering operations. Intersil Pb-free products are MSL classified at Pb-free peak reflow temperatures that meet or exceed the Pb-free requirements of IPC/JEDEC J STD-020.

Pinout

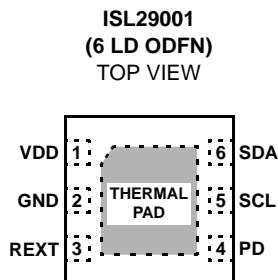

Features

- Human eye response
- Temperature compensated
- IR rejection
- 15-bit effective resolution
- Adjustable resolution: 3 to 15 counts per lux
- Simple output code, directly proportional to lux
- 0.3lux to 10,000lux range
- 50Hz/60Hz rejection
- I²C interface
- 2.5V to 3.3V supply
- 6 Ld ODFN (2.1mm x 2mm)
- Pb-free package (RoHS compliant)

Applications

- Ambient light sensing
- Ambient backlight control
- Temperature control systems
- Contrast control
- Camera light meters
- Lighting controls
- HVAC

Block Diagram

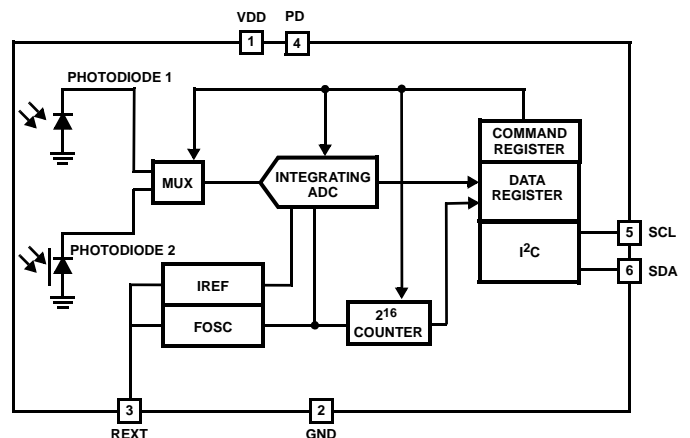

Absolute Maximum Ratings ($T_A = 25^\circ\text{C}$)

Maximum Supply Voltage between V_{DD} and GND	3.6V	Maximum Die Temperature	+125°C
I ² C Bus Pin Voltage (SCL, SDA)	-0.2V to 5.5V	Storage Temperature	-45°C to +100°C
I ² C Bus Pin Current (SCL, SDA)	<10mA	ESD Voltage	2kV
R _{ext} Pin Voltage	-0.2V to 3.6V		
Operating Temperature	-45°C to +85°C		

CAUTION: Stresses above those listed in "Absolute Maximum Ratings" may cause permanent damage to the device. This is a stress only rating and operation of the device at these or any other conditions above those indicated in the operational sections of this specification is not implied.

IMPORTANT NOTE: All parameters having Min/Max specifications are guaranteed. Typical values are for information purposes only. Unless otherwise noted, all tests are at the specified temperature and are pulsed tests, therefore: $T_J = T_C = T_A$

Electrical Specifications $V_{DD} = 3V$, $T_A = 25^\circ\text{C}$, $R_{EXT} = 100k\Omega$, internally controlled integration timing (Note 1), unless otherwise specified.

PARAMETER	DESCRIPTION	CONDITION	MIN	TYP	MAX	UNIT
V_{DD}	Power Supply Range		2.25		3.63	V
I_{DD}	Supply Current			0.28	0.33	mA
I_{DD1}	Supply Current	Software disabled		0.09	0.10	mA
I_{DD2}	Supply Current	PD = 3V			0.5	μA
FUPD	Internal Update Time	Mode 1 & Mode 2 (Note 2)	85	105	126	ms
Fosc	Internal Oscillator Frequency			312		kHz
F ^{I²C}	I ² C Clock Rate	(Note 3)	1		400	kHz
DATA0	ADC Code	Ev = 0lux			1	Counts
DATA1	ADC Code	Full scale ADC count value			32768	Counts
DATA2	ADC Code	Ev = 300lux, fluorescent light, Mode 1 (Note 4)	738	983	1254	Counts
DATA3	ADC Code	Ev = 300lux, fluorescent light, Mode 2 (Note 4)		98		Counts
V_{REF}	Voltage of R _{EXT} Pin		0.487	0.51	0.533	V
V_{TL}	SCL & SDA Threshold LO	(Note 5)		1.05		V
V_{TH}	SCL & SDA Threshold HI	(Note 5)		1.95		V
I_{SDA}	SDA Current Sinking Capability		3	5		mA
I_{PD}	PD Pin Leakage Current	PD = V_{DD}		0.1		μA
t_{on}	Enable Time	PD = HI to LO		2		μs
t_{off}	Disable Time	PD = LO to HI		50		ns

NOTES:

1. See Principle of Operation
2. There are three modes of the ADC's operations. In Mode 1, the ADC integrates the current of the photodiode which is sensitive to visible and infrared light. In Mode 2, the ADC integrates the current of the photodiode which is sensitive only to infrared light.
3. Minimum I²C Clock Rate is guaranteed by design.
4. Fluorescent light is substituted by an LED at production.
5. The voltage threshold levels of the SDA and SCL pins are V_{DD} dependent: $V_{TL} = 0.35 \cdot V_{DD}$. $V_{TH} = 0.65 \cdot V_{DD}$.

Pin Descriptions

PIN NUMBER	PIN NAME	DESCRIPTION	
1	VDD	Positive supply. Connect this pin to a clean 2.5V to 3.3V supply.	
2	GND	Ground pin. The thermal pad is connected to the GND pin.	
3	REXT	External resistor pin is for the ADC reference current, the integration time adjustment in internal timing mode, and lux range/resolution adjustment. 100kΩ 1% tolerance resistor recommended.	
4	PD	Power-down pin. This pin is active-high. Applying a logic “high” to this pin will put the device into power down mode.	
5	SCL	I ² C serial clock	The I ² C bus lines can pulled above V _{DD} , 5.5V max.
6	SDA	I ² C serial data	

Typical Performance Curves R_{ext} = 100kΩ

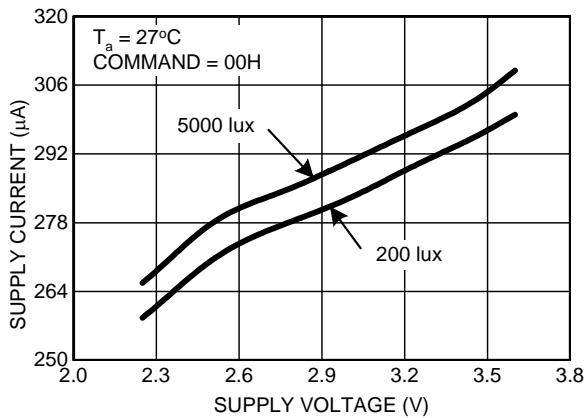

FIGURE 1. SUPPLY CURRENT vs SUPPLY VOLTAGE

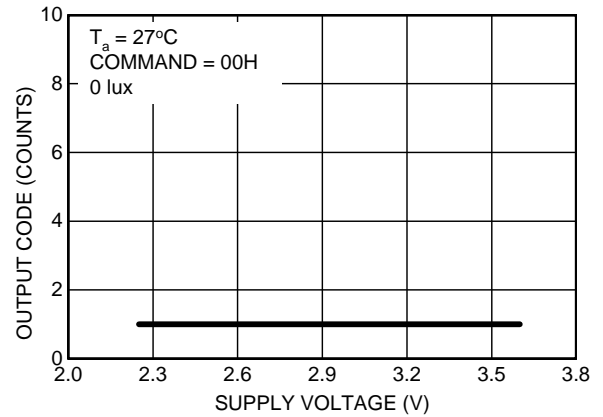

FIGURE 2. OUTPUT CODE FOR 0LUX vs SUPPLY VOLTAGE

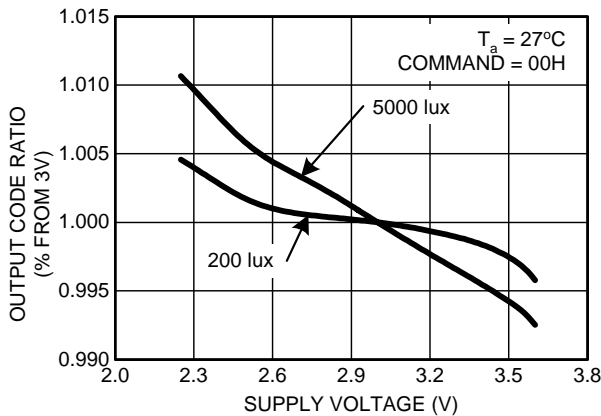

FIGURE 3. OUTPUT CODE vs SUPPLY VOLTAGE

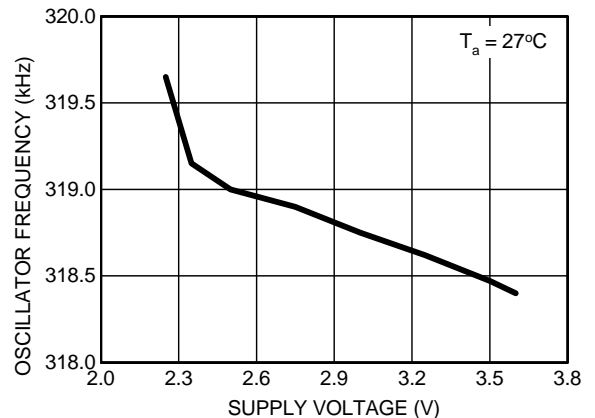

FIGURE 4. OSCILLATOR FREQUENCY vs SUPPLY VOLTAGE

Typical Performance Curves $R_{ext} = 100k\Omega$ (Continued)

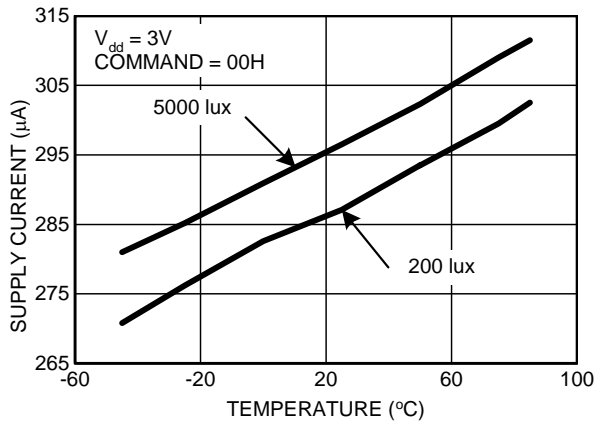

FIGURE 5. SUPPLY CURRENT vs TEMPERATURE

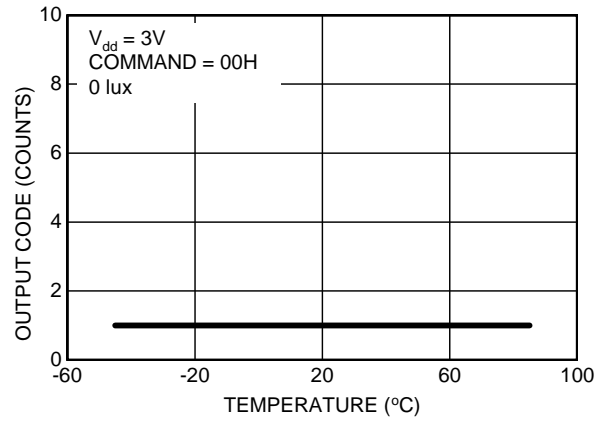

FIGURE 6. OUTPUT CODE FOR 0LUX vs TEMPERATURE

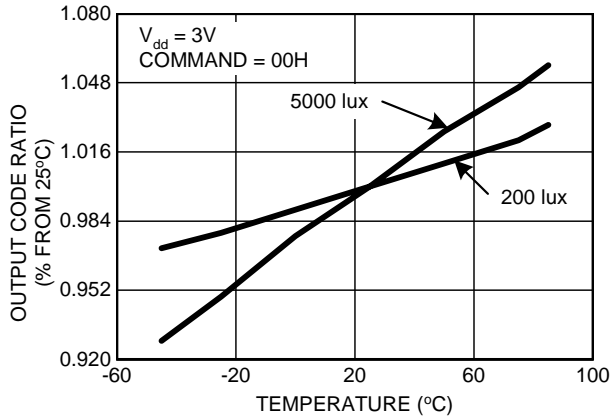

FIGURE 7. OUTPUT CODE vs TEMPERATURE

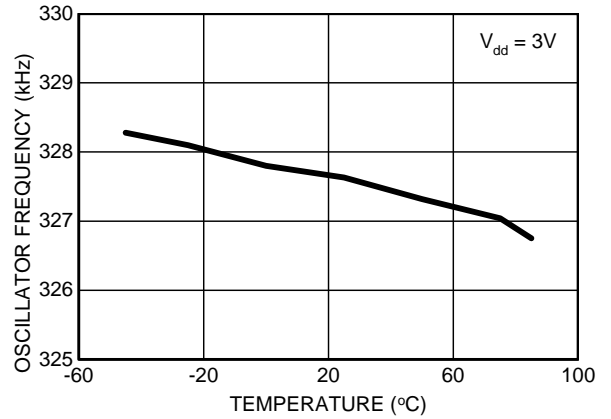

FIGURE 8. OSCILLATOR FREQUENCY vs TEMPERATURE

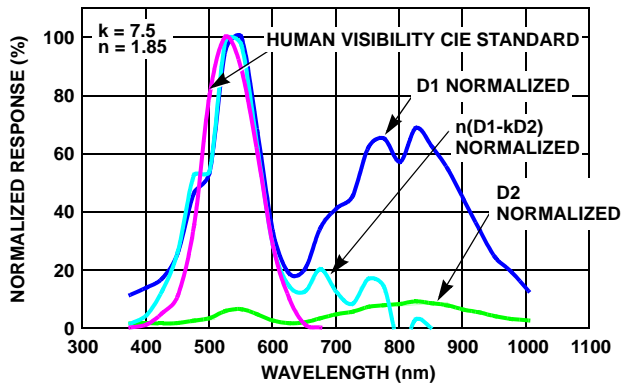

FIGURE 9. SPECTRAL RESPONSE

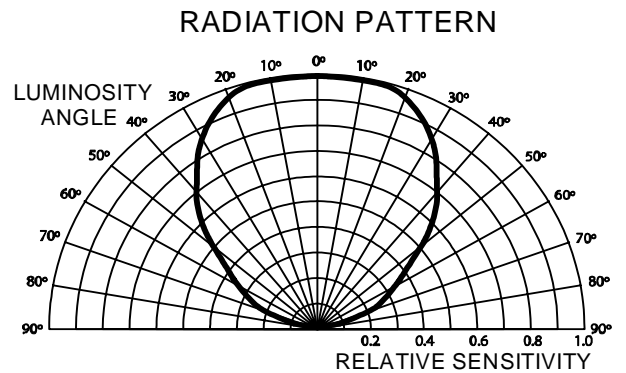

FIGURE 10. RADIATION PATTERN

Principles of Operation

Photodiodes and ADC

The ISL29001 contains two photodiodes. One of the photodiodes is sensitive to visible and infrared light (Diode 1) while the other diode (Diode 2) is used for temperature compensation (leakage current cancellation) and IR rejection. The ISL29001 also contains an on-chip integrating analog-to-digital converter (ADC) to convert photodiode currents into digital data.

The ADC has three operating modes with two timing controls. (Please consult Table 1 for a complete list of modes.) In the first operating mode, the ADC only integrates Diode 1's current, and the digital output format is 16-bit unsigned-magnitude. In second operating mode, the ADC's operation is the same, except Diode 2's current is integrated. In the third operating mode, the ADC integrates Diode 2's current first, then Diode 1's current. The total integration time is doubled, and the digital output is the difference of the two photodiode currents (Diode 1's current - Diode 2's current). In this mode, the digital output format is 16-bit 2's-complement. Any of the three operating modes can be used with either of the two timing controls (either internally or externally controlled integration timing).

The interface to the ADC is implemented using the standard I²C interface.

I²C Interface

The ISL29001 contains a single 8-bit command register that can be written via the I²C interface. The command register defines the operation of the device, which does not change until the command register is overwritten.

The ISL29001 contains four 8-bit data registers that can be read via the I²C interface. The first two data registers contain the ADC's latest digital output, while the second two registers contain the number of clock cycles in the previous integration period.

The ISL29001's I²C address is hardwired internally as 1000100.

Figure 11A shows a write timing diagram sample. Figure 11B shows a sample two-byte read. The I²C bus master always drives the SCL (clock) line, while either the master or the slave can drive the SDA (data) line. Every I²C transaction begins with the master asserting a start condition (SDA falling while SCL remains high). The following byte is driven by the master, and includes the slave address and read/write bit. The receiving device is responsible for pulling SDA low during the acknowledgement period.

Any writes to the ISL29001 overwrite the command register, changing the device's mode. Any reads from the ISL29001 return two or four bytes of sensor data and counter value, depending upon the operating mode. Neither the command register nor the data registers have internal addresses, and none of the registers can be individually addressed.

Every I²C transaction ends with the master asserting a stop condition (SDA rising while SCL remains high).

I²C Transaction Flow

To WRITE, the master sends slave address 44(hex) plus the write bit. Then master sends the ADC command to the device which defines its operation. As soon as the ISL29001 receives the ADC command, it will execute and then store the readings in the register after the analog-to-digital conversion is complete. While the ISL29001 is executing the command and also after the execution, the I²C bus is available for transactions other than the ISL29001. After command execution, sensor data readings are stored in the registers. Note that if a READ is received before the execution is finished, the data retrieved is previous data sensor reading. Typical integration/conversion time is 100ms (for R_{EXT} = 100k and internal timing mode). It is recommended that a READ is sent 120ms later because the fosc variation is 20%.

The operation of the device does not change until the command register is overwritten. Hence, when the master sends a slave address 44(hex) and a write bit, the ISL29001 will repeat the same command from the previous WRITE transaction.

To READ, master sends slave address 44(hex) plus the read bit. Then ISL29001 will hold the SDA line to send data to master. Note that the master need not send an address register to access the data. As soon as the ISL29001 receives the read bit. It will send 4 bytes. The 1st byte is the LSB of the sensor reading. The 2nd byte is the MSB of the sensor reading. The 3rd byte is LSB of the counter reading. The 4th byte is the MSB of the counter reading. If internal timing mode is selected, only the 1st and 2nd data byte are necessary; the master can assert a stop after the 2nd data byte is received.

For more information about the I²C standard, please consult the Philips® I²C specification documents.

Command Register

The command register is used to define the ADC's operations. Table 1 shows the primary commands used to control the ADC.

Note that there are two classes of operating commands: three for internal timing, and three for external (arbitrary) timing.

When using any of the three internal timing commands, the device self-times each conversion, which is nominally 100ms (with R_{EXT} = 100kΩ).

When using any of the three external timing commands, each command received by the device ends one conversion and begins another. The integration time of the device is thus the time between one I²C external timing command and the next. The integration time can be between 1ms and 100ms. The external timing commands can be used to synchronize the ADC's integrating time to a PWM dimming frequency in a backlight system in order to eliminate noise.

TABLE 1. COMMAND REGISTERS AND FUNCTIONS

COMMAND	FUNCTION
8cH	ADC is powered-down.
0cH	ADC is reset.
00H	ADC converts Diode 1's current (I_{DIODE1}) into unsigned-magnitude 16-bit data. The integration is internally timed at 100ms per integration.
04H	ADC converts Diode 2's current (I_{DIODE2}) into unsigned-magnitude 16-bit data. The integration is internally timed at 100ms per integration.
08H	ADC converts $I_{DIODE1}-I_{DIODE2}$ into 2's-complement 16-bit data. The total integration is internally timed at 200ms per integration.
30H	ADC converts Diode 1's current (I_{DIODE1}) into unsigned-magnitude 16-bit data. The integration is externally timed; each 30H command sent to the device ends one integration period and begins another.
34H	ADC converts Diode 2's current (I_{DIODE1}) into unsigned-magnitude 16-bit data. The integration is externally timed; each 34H command sent to the device ends one integration period and begins another.
38H	ADC converts $I_{DIODE1}-I_{DIODE2}$ into 2's-complement 16-bit data. The integration is externally timed; each 38H command sent to the device ends one integration period and begins another.
1xxx_xxxxB	I ² C communication test. The value written to the command register can be read back via the I ² C bus.

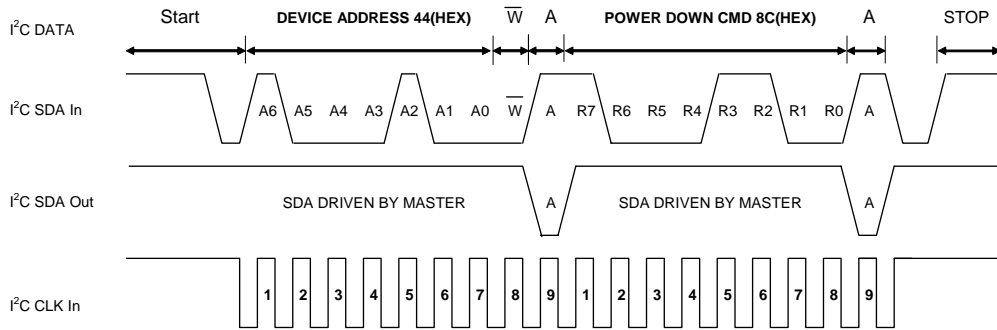

FIGURE 11A. I²C WRITE TIMING DIAGRAM SAMPLE

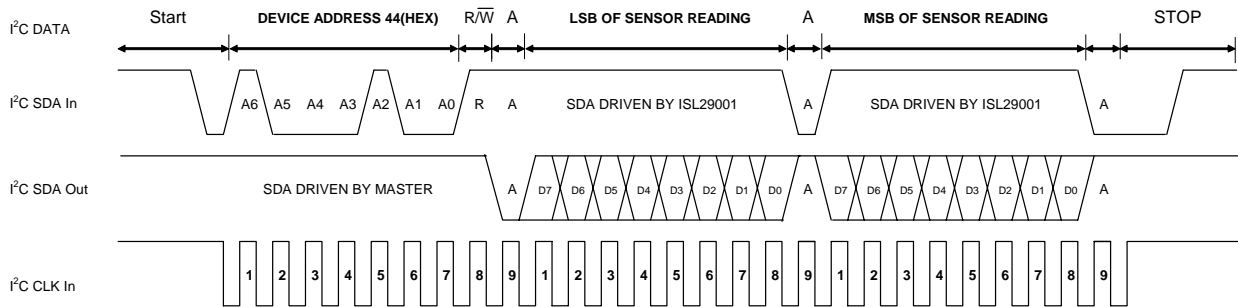

FIGURE 11B. I²C READ TIMING DIAGRAM SAMPLE

FIGURE 11.

Data Registers

The ISL29001 contains four 8-bit data registers. These registers cannot be specifically addressed, as is conventional with other I²C peripherals; instead, performing a read operation on the device always returns all available registers in ascending order. See Table 2 for a description of each register.

TABLE 2. DATA REGISTERS

ADDRESS	CONTENTS
00H	Least-significant byte of most recent sensor reading.
01H	Most-significant byte of most recent sensor reading.
02H	Least-significant byte of integration counter value corresponding to most recent sensor reading.
03H	Most-significant byte of integration counter value corresponding to most recent sensor reading.

The first two 8-bit data registers contain the most recent sensor reading. The meaning of the specific value stored in these data registers depends on the command written via the I²C interface; see Table 1 for information on the various commands. The first byte read over the I²C interface is the least-significant byte; the second is the most significant. This byte ordering is often called "little-endian" ordering.

The third and fourth 8-bit data registers contain the integration counter value corresponding to the most recent sensor reading. The ISL29001 includes a free-running oscillator, each cycle of which increments a 16-bit counter. At the end of each integration period, the value of this counter is made available in these two 8-bit registers. Like the sensor reading, the integration counter value is read across the I²C bus in little-endian order.

Note that the integration counter value is only available when using one of the three externally-timed operating modes; when using internally-timed modes, the device will NAK after the two-byte sensor reading has been read.

Internal Timing

When using one of the three internal timing modes, each integration period of the ISL29001 is timed by 32,768 clock cycles of an internal oscillator. The nominal frequency of the internal oscillator is 327.6kHz, which provides 100ms internally-timed integration periods. The oscillator frequency is dependent upon an external resistor, R_{ext}, and can be adjusted by selecting a different resistor value. The resolution and maximum range of the device are also affected by changes in R_{ext}; see below.

The oscillator frequency can be calculated with the following equation:

$$f_{osc} = 327.6\text{kHz} \cdot \frac{100\text{k}\Omega}{R_{ext}} \quad (\text{EQ. 1})$$

Accordingly, the integration time, T_{int}, is also a function of R_{ext}.

$$T_{int} = 100\text{ms} \cdot \frac{R_{ext}}{100\text{k}\Omega} \quad (\text{EQ. 2})$$

The full scale range in lux, FSR, is also scaled by R_{ext}.

$$\text{FSR} = 10000\text{lux} \cdot \frac{100\text{k}\Omega}{R_{ext}} \quad (\text{EQ. 3})$$

R_{ext} is nominally 100kΩ, and provides 100ms internal timing and a 1-10,000lux range for Diode 1. Doubling this resistor value to 200kΩ halves the internal oscillator frequency, providing 200ms internal timing. In addition, the maximum lux range of Diode 1 is also halved, from 10,000lux to 5,000lux, and the resolution is doubled, from 3.3 counts per lux to 6.6 counts per lux.

The acceptable range of this resistor is 50kΩ (providing 50ms internal timing, 20,000lux maximum reading, ~1.6 counts per lux) to 500kΩ (500ms internal timing, 2,000lux maximum reading, ~16 counts per lux).

TABLE 3. R_{ext} RESISTOR SELECTION GUIDE

R _{ext} (kΩ)	INTEGRATION TIME (ms)	LUX RANGE (lux)	RESOLUTION, COUNTS/LUX
50 (Min)	50	20,000	1.6
100 Recommended	100	10,000	3
200	200	5,000	6
500 (Max)	500	2,000	16

When using one of the three internal timing modes, the ISL29001's resolution is determined by the ratio of the max lux range to 32,768, the number of clock cycles per integration.

The following equations describe the light intensity as a function of the sensor reading, and as a function of the external resistor.

$$E(\text{Lux}) = \frac{\text{FSR}}{32768} \cdot \text{Data1} \quad (\text{EQ. 4})$$

$$E(\text{Lux}) = \frac{1}{32768} \cdot \frac{10,000\text{lux}}{(R_{ext}/100\text{k}\Omega)} \cdot \text{Data1}$$

where E is the measured light intensity, Data1 is the sensor reading, and R_{ext} is external resistor value.

External Timing

When using one of the three external timing modes, each integration period of the ISL29001 is determined by the time which passes between consecutive external timing commands received over the I²C bus. The user starts the integration by sending an external command and stops the integration by sending another external command. The integration time, T_{int}, therefore is determined by the following equation:

$$T_{int} = \frac{i_{I2C}}{f_{I2C}} \quad (\text{EQ. 5})$$

where:

i_{I2C} is the number of I²C clock cycles to obtain the T_{int}.
f_{I2C} is the I²C operating frequency

The internal oscillator, f_{OSC} , operates identically in both the internal and external timing modes, with the same dependence on R_{ext} . However, when using one of the three external timing modes, the number of clock cycles per integration is no longer fixed at 32,768, but varies with the chosen integration time, and is limited to 65,536. In order to avoid erroneous lux readings the integration must be short enough not to allow an overflow in the counter register.

$$T_{int} < \frac{65,536}{f_{OSC}} \quad (\text{EQ. 6})$$

where:

T_{int} = user defined integration time

$f_{OSC} = 327.6\text{kHz} \cdot 100\text{k}\Omega / R_{ext}$. ISL29001's internal oscillator. Not to be confused with the I²C's frequency.

R_{ext} = user defined external resistor to adjust f_{OSC} . 100k Ω recommended.

The number of clock cycles in the previous integration period is provided in the third and fourth bytes of data read across the I²C bus. This two-byte value is called the integration counter value.

When using one of the three external timing modes, the ISL29001's resolution varies with the integration time. The resolution is determined by the ratio of the max lux range to the number of clock cycles per integration.

The following equations describe the light intensity as a function of sensor reading, integration counter value, and integration time:

$$E(\text{Lux}) = \frac{10,000\text{lux}}{(R_{ext}/100\text{k}\Omega)} \cdot \frac{\text{Data1}}{\text{Data2}} \quad (\text{EQ. 7})$$

where E is the measured light intensity, Data1 is the sensor reading, Data2 is the integration counter value, T is the integration time, and R_{ext} is external resistor value.

Noise Rejection and Integration Time

In general, integrating type ADC's have an excellent noise-rejection characteristics for periodic noise sources whose frequency is an integer multiple of the integration time. For instance, a 60Hz AC unwanted signal's sum from 0ms to $n \cdot 16.66\text{ms}$ ($n = 1, 2, \dots, n_i$) is zero. Similarly, setting the ISL29001's integration time to an integer multiple of periodic noise signal greatly improves the light sensor output signal in the presence of noise. The integration time, T_{int} , of the ISL29002 is set by an external resistor R_{ext} . See Equation 3.

Design Example 1

Using the ISL29001, determine a suitable integration time, T_{int} , that will ignore the presence of both 60Hz and 50Hz noise. Accordingly, specify the R_{ext} value. Given that the I²C clock is at $f_{I2C} = 10\text{kHz}$.

Solution 1 - Using Internal Timing

$T_{int} = n(1/60\text{Hz}) = m(1/50\text{Hz})$. In order to achieve both 60Hz and 50Hz AC rejection, the integration time needs to be adjusted to coincide with an integer multiple of the AC noise cycle times.

$n/m = 60\text{Hz}/50\text{Hz} = 6/5$. The first instance of integer values at which T_{int} rejects both 60Hz and 50Hz is when $m = 5$, and $n = 6$.

$$T_{int} = 6(1/60\text{Hz}) = 5(1/50\text{Hz}) = 100\text{ms}$$

From Equation 3:

$R_{ext} = T_{int} \cdot (100\text{k}\Omega/100\text{ms}) = 100\text{k}\Omega$. By populating $R_{ext} = 100\text{k}\Omega$, the ISL29001 defaults to 100ms integration time and will reject the presence of both 60Hz and 50Hz power line signals.

Solution 2 - Using External Timing

From solution 1, the desired integration time is 100ms. Note that the R_{ext} resistor does not determine the integration time when using external timing mode. Instead, the integration and the 16-bit counter starts when an external timing mode command is sent and end when another external timing mode is sent. In other words, the time between two external timing mode command is the integration time. The programmer determines how many clock cycles to wait between two external timing commands.

$i_{I2C} = f_{I2C} \cdot T_{int}$, where i_{I2C} = number of I²C cycles

$$i_{I2C} = 10\text{kHz} \cdot 100\text{ms}$$

$i_{I2C} = 1,000$ I²C clock cycles. An external timing command 1,000 cycles after another external timing command rejects both 60Hz and 50Hz AC noise signals.

IR Rejection

Any filament type light source has a high presence of infrared component invisible to the human eye. A white fluorescent lamp, on the other hand has a low IR content. As a result, output sensitivity may vary depending on the light source. Maximum attenuation of IR can be achieved by properly scaling the readings of Diode1 and Diode2. The user obtains data reading from sensor diode 1, D1, which is sensitive to visible and IR, then reading from sensor diode 2, D2 which is mostly sensitive from IR. The graph on Figure 9 shows the effective spectral response after applying Equation 8 of the ISL29001 from 400nm to 1000nm. The equation below describes the method of cancelling IR in internal timing mode.

$$D3 = n(D1 - kD2) \quad (\text{EQ. 8})$$

Where:

data = lux amount in number of counts less IR presence

D1 = data reading of Diode 1

D2 = data reading of Diode 2

$n = 1.85$. This is a fudge factor to scale back the sensitivity up to ensure Equation 4 is valid.

$k = 7.5$. This is a scaling factor for the IR sensitive Diode 2.

Flat Window Lens Design

A window lens will surely limit the viewing angle of the ISL29001. The window lens should be placed directly on top of the ISL29001. The thickness of the lens should be kept at minimum to minimize loss of power due to reflection and also to minimize loss of loss due to absorption of energy in the plastic material. A thickness of $t = 1\text{mm}$ is recommended for a window lens design. The bigger the diameter of the window lens the wider the viewing angle is of the ISL29001. Table 4 shows the recommended dimensions of the optical window to ensure both 35° and 45° viewing angle. These dimensions are based on a window lens thickness of 1.0mm and a refractive index of 1.59 .

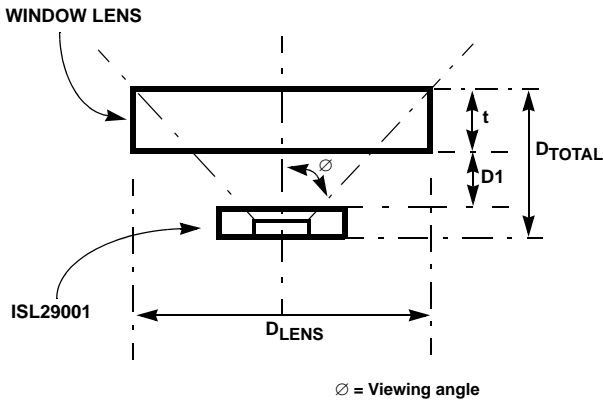

FIGURE 12. FLAT WINDOW LENS

TABLE 4. RECOMMENDED DIMENSIONS FOR A FLAT WINDOW DESIGN

D _{TOTAL}	D ₁	D _{LENS} @ 35 VIEWING ANGLE	D _{LENS} @ 45 VIEWING ANGLE
1.5	0.50	2.25	3.75
2.0	1.00	3.00	4.75
2.5	1.50	3.75	5.75
3.0	2.00	4.30	6.75
3.5	2.50	5.00	7.75

t = 1 Thickness of lens
D₁ Distance between ISL29001 and inner edge of lens
D_{LENS} Diameter of lens
D_{TOTAL} Distance constraint between the ISL29001 and lens outer edge

* All dimensions are in mm.

Window with Light Guide Design

If a smaller window is desired while maintaining a wide effective viewing angle of the ISL29001, a cylindrical piece of transparent plastic is needed to trap the light and then focus and guide the light on to the ISL29001. Hence the name light guide or also known as light pipe. The pipe should be placed directly on top of the ISL29001 with a distance of $D_1 = 0.5\text{mm}$ to achieve peak performance. The light pipe should have minimum of 1.5mm in diameter to ensure that whole area of the sensor will be exposed. See Figure 13.

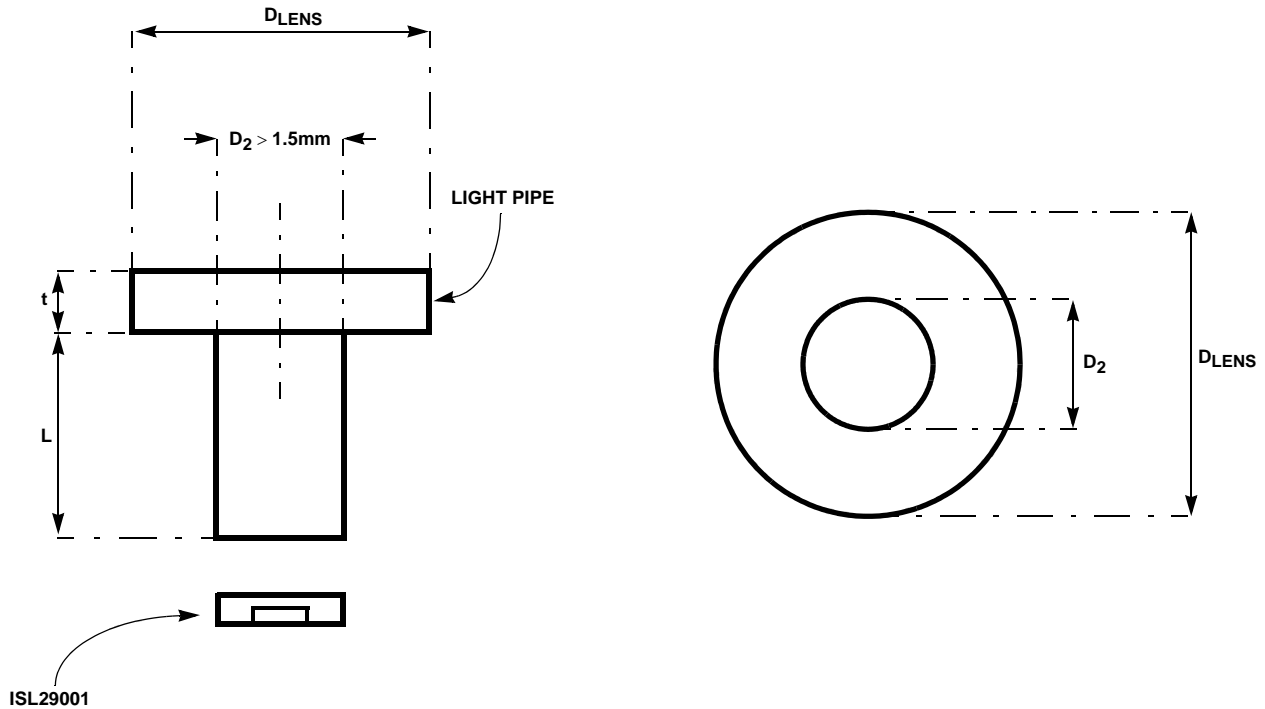

FIGURE 13. WINDOW WITH LIGHT GUIDE/PIPE

Typical Circuit

A typical application circuit is shown in Figure 14.

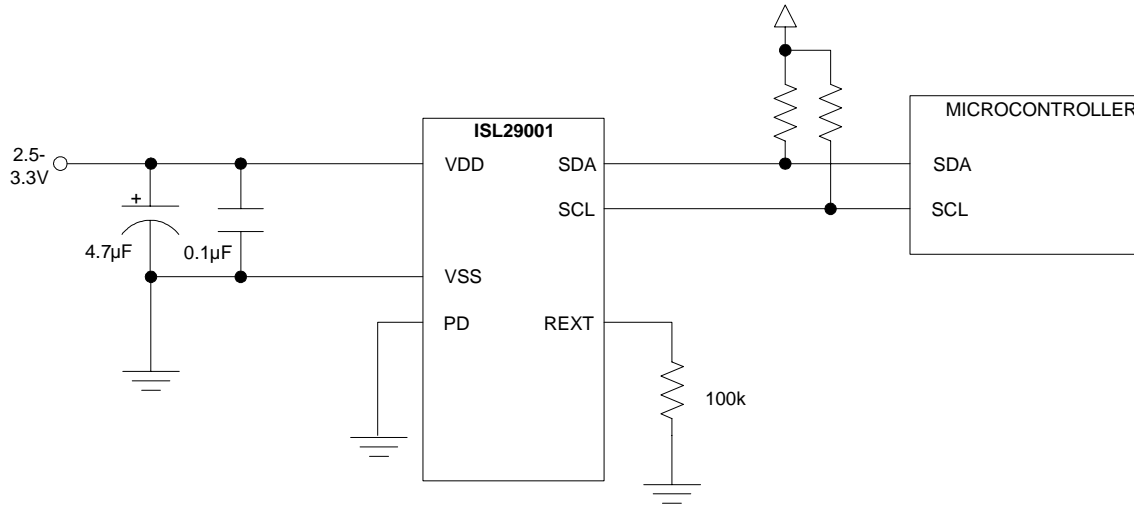

FIGURE 14. TYPICAL CIRCUIT

Suggested PCB Footprint

See Figure 15. Footprint pads should be a nominal 1-to-1 correspondence with package pads. The large, exposed central die-mounting paddle in the center of the package requires neither thermal nor electrical connection to the PCB, and such connection should be avoided.

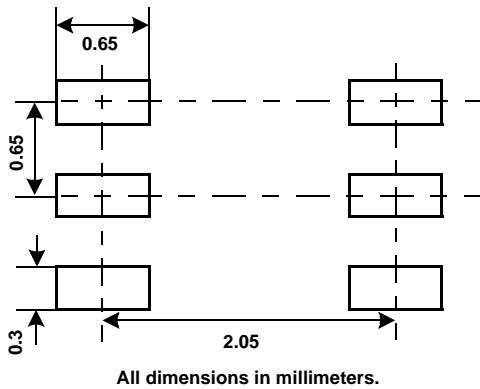

FIGURE 15. SUGGESTED PCB FOOTPRINT

Layout Considerations

The ISL29001 is relatively insensitive to layout. Like other I²C devices, it is intended to provide excellent performance even in significantly noisy environments. There are only a few considerations that will ensure best performance.

Route the supply and I²C traces as far as possible from all sources of noise. Use two power-supply decoupling capacitors, 4.7µF and 0.1µF, placed close to the device.

Soldering Considerations

Convection heating is recommended for reflow soldering; direct-infrared heating is not recommended. The ISL29001's plastic ODFN package does not require a custom reflow soldering profile, and is qualified to 260°C. A standard reflow soldering profile with a 260°C maximum is recommended.

Special Handling

ODFN6 is rated as JEDEC moisture level 4. Standard JEDEC Level 4 procedure should be followed: 72hr floor life at less than 30°C 60% RH. When baking the device, the temperature required is 110°C or less due to special molding compound.

Optical Dual Flat No-Lead Family (ODFN)

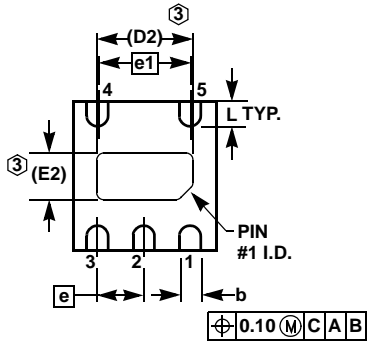
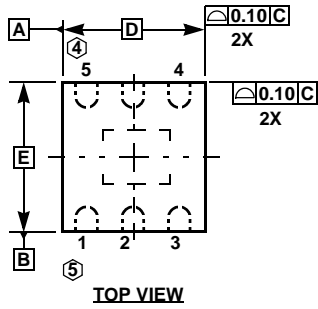

MDP0052

OPTICAL DUAL FLAT NO-LEAD FAMILY

SYMBOL	ODFN5	ODFN6	ODFN8	TOLERANCE	NOTE
A	0.70	0.70	0.70	±0.05	
A1	0.02	0.02	0.02	+0.03/-0.02	
b	0.30	0.30	0.30	±0.05	
c	0.20	0.20	0.20	Reference	2
D	2.00	2.00	3.00	Basic	
D2	1.35	1.35	2.29	Reference	3
E	2.10	2.10	3.00	Basic	
E2	0.65	0.65	1.40	Reference	3
e	0.65	0.65	0.65	Basic	
e1	1.30	1.30	1.95	Basic	
L	0.35	0.35	0.40	±0.05	

Rev. 4 5/06

NOTES:

1. Dimensioning and tolerancing per ASME Y14.5M-1994.
2. Exposed lead at side of package is a non-functional feature.
3. Dimension D2 and E2 define the size of the exposed pad.
4. ODFN 5 Ld version has no center lead (shown as dashed line).

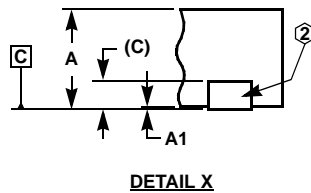
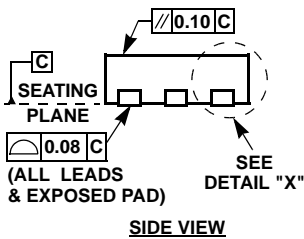
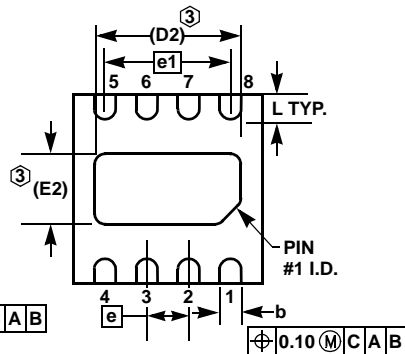
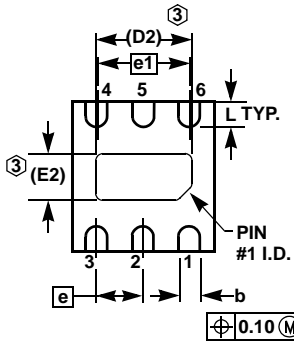

All Intersil U.S. products are manufactured, assembled and tested utilizing ISO9000 quality systems. Intersil Corporation's quality certifications can be viewed at www.intersil.com/design/quality

Intersil products are sold by description only. Intersil Corporation reserves the right to make changes in circuit design, software and/or specifications at any time without notice. Accordingly, the reader is cautioned to verify that data sheets are current before placing orders. Information furnished by Intersil is believed to be accurate and reliable. However, no responsibility is assumed by Intersil or its subsidiaries for its use; nor for any infringements of patents or other rights of third parties which may result from its use. No license is granted by implication or otherwise under any patent or patent rights of Intersil or its subsidiaries.

For information regarding Intersil Corporation and its products, see www.intersil.com