

147-880 to 147-887

Gearbox & Motor Fitting Procedure

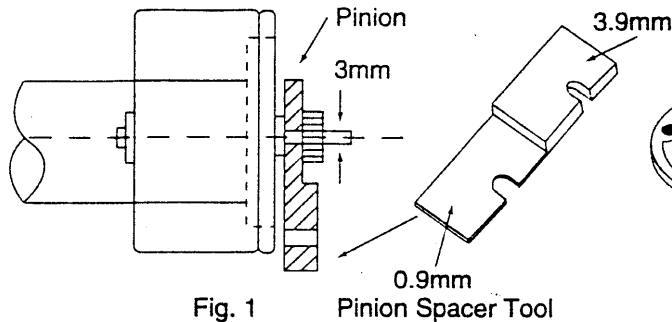
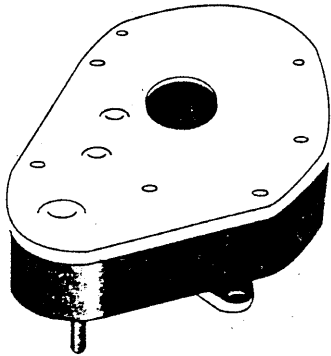

Fig. 1

Pinion Spacer Tool

Fig. 2
Adaptor Plate

Gearbox Kit: List of Contents

- a. Gearbox
- b. 6 Fixing Screws for use with 12V dc Servo Motor (147-875)
- c. 12V dc Servo Motor Adaptor Plate
- d. ac Stepper/Synchronous Motor Spring Clip
- e. Motor Pinion (3mm diameter bore suitable for loctite fixing)
- f. Pinion Spacer/fitting tool

The Motor Pinion should be fitted to the motor shaft using loctite Grade 601 (146-317) and the pinion tool as shown above.

The strongest bond is obtained if the motor shaft surface is lightly roughened before the pinion fitting operating commences. All surfaces should be dry, clean and free from oil and grease.

Procedure

Slip the drive pinion over the motor shaft and loctite in position using the pinion spacing tool provided. ensure that the motor shaft is in the horizontal plane. Use the spacer to position the pinion as shown in Fig. 1 using the face of the motor mounting spigot as a reference. When using the dc servo motor 147-875 the adaptor kit Fig. 2 is required and used as a reference. The position of the pinion requires different spacer heights depending on the Gearbox type as listed below:

Gearbox Order Code	Spacer Height	Ratio	dc Servo Speed RPM	Sync. Motor Speed	Stepper Motor Step Angle
147-880	3.9mm	25:3	360	30 RPM	0.9°
147-881	0.9mm	25:2	250	20 RPM	0.6°
147-882	0.9mm	25:1	120	10 RPM	0.3°
147-883	0.9mm	50:1	60	5 RPM	0.15°
147-884	3.9mm	125:1	25	2 RPM	0.06°
147-885	3.9mm	250:1	12	1 RPM	0.03°
147-886	3.9mm	1,250:1	2.5	12 Rev/hr	0.36'
147-887	0.9mm	15,000:1	0.2	1 Rev/hr	0.03'

Attaching Motor to Gearbox

1. 12 Volt dc Servo Motor (147-875)

Secure the Adaptor Plate (Fig. 2) to the Motor through the countersunk holes on the underside of the adaptor plate using the three small screws supplied. Attach the motor with the adaptor plate to the gearbox using the three larger screws supplied.

2. Synchronous and Stepping Motors WITHOUT mounting ears (147-877 & 147-879)

Offer the motor to the gearbox. Place the spring clip supplied with the gearbox kit over the spigot to the rear of the motor then locate the ears of the spring clip in the slots on the gearbox.

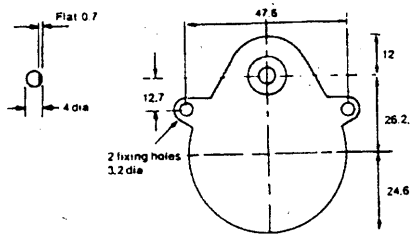

Gearbox

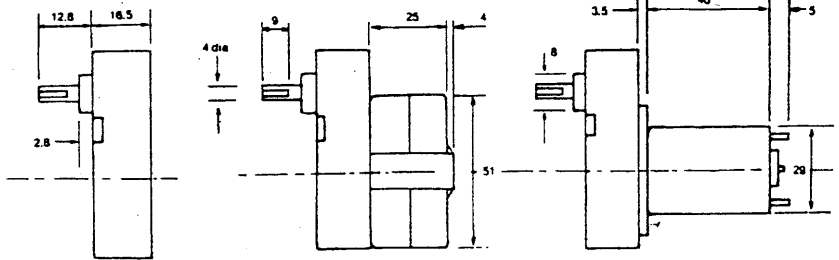

Gearbox with Synchronous Stepping Motor Fitted Without Mounting Ears

Gearbox with 12V dc Servo Motor Fitted

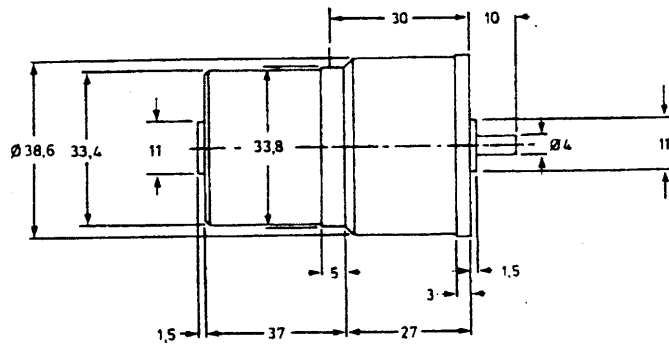
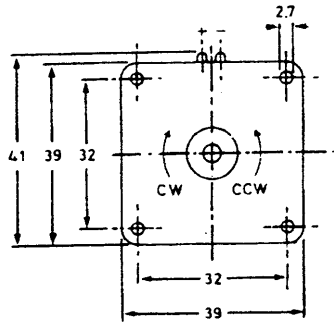

12V Geared Motors

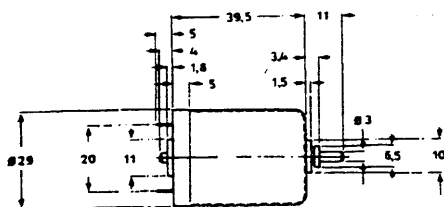

12V dc Servo Motor

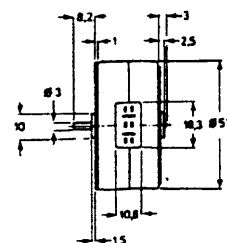
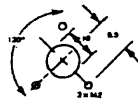

Synchronous or Stepping Motor With Mounting Ears

