

ANTENNA PRODUCTS

DATA SHEET

3216 Ceramic Chip Antenna for Bluetooth/WLAN Application

R&D	Print date 05/09/06						
	3216 Ceramic Chip Antenna for Bluetooth/WLAN Application			CAN4311712002453K			2005.4.4
Mars Liu	C.T.Lee			Page 1	sheet 190-1		A4
spec.doc	Yageo Taiwan						

3216 Ceramic Chip Antenna for Bluetooth/WLAN Application

Preliminary Product Specification

Quick Reference Data

Centre Frequency	2.45 GHz* ¹
Bandwidth	at least 100 MHz* ²
VSWR	2.5 (Max.)* ²
Polarization	Linear
Azimuth Beamwidth	Omni-directional
Peak Gain	3.1 dBi* ²
Impedance	50Ω
Operating Temperature	-25~85 °C
Termination	Ni / Sn (Environmentally-Friendly Leadless)
Resistance to soldering heats	260°C , 10sec.
Maximum Power	1W

¹ All the technical data and information contained herein are subject to change without prior notice

² Testing under evaluation board of page2

R&D	Print date 05/09/06						
	3216 Ceramic Chip Antenna for Bluetooth/WLAN Application				CAN4311712002453K		2005.4.4
Mars Liu	C.T.Lee			Page 2	sheet 190-2		A4
spec.doc	Yageo Taiwan						

1. Mechanical Data (3.2 x 1.6 x 1.2 mm³)

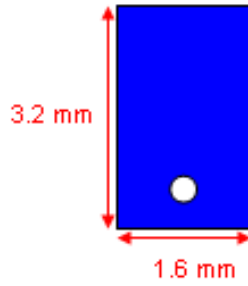

Unit: mm

2. Evaluation Board Dimension and Outlook

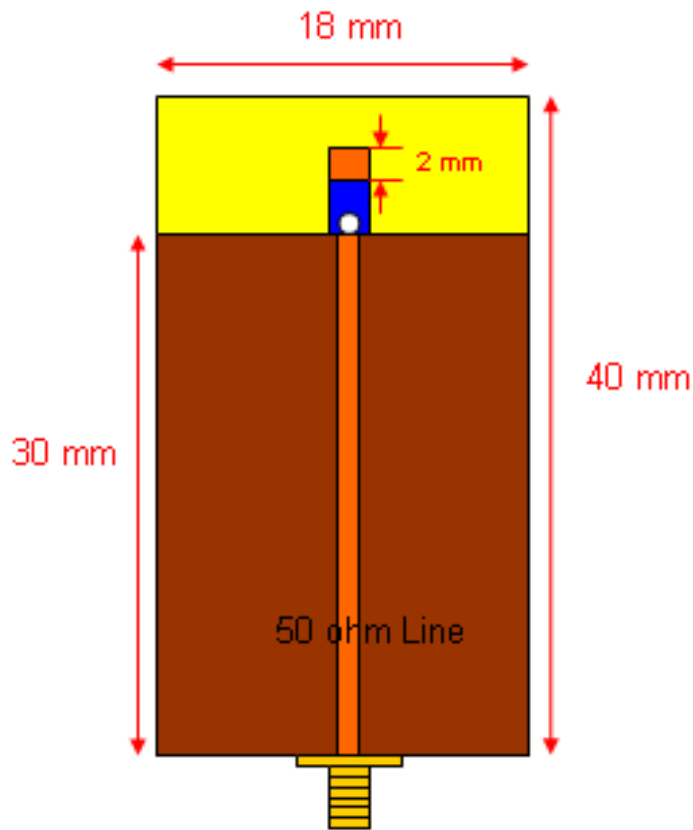

Unit: mm

R&D	Print date 05/09/06							
	3216 Ceramic Chip Antenna for Bluetooth/WLAN Application					CAN4311712002453K		2005.4.4
Mars Liu	C.T.Lee			Page 3	sheet 190-3		A4	
spec.doc	Yageo Taiwan							

3. Soldering Pads Dimension

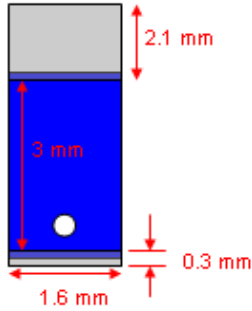

Unit: mm

4. Return Loss

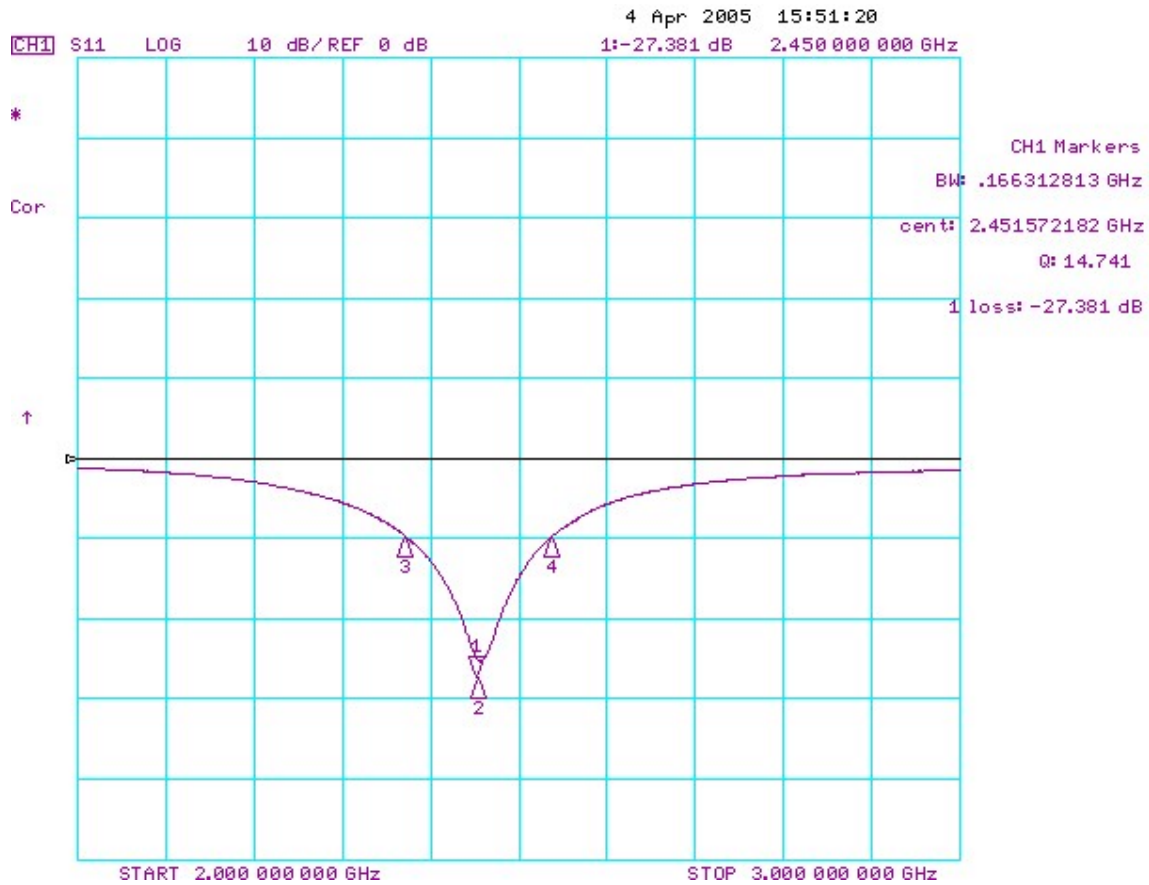

R&D	Print date 05/09/06					2005.4.4
	3216 Ceramic Chip Antenna for Bluetooth/WLAN Application			CAN4311712002453K		
Mars Liu	C.T.Lee			Page 4	sheet 190-4	A4
spec.doc	Yageo Taiwan					

5. VSWR

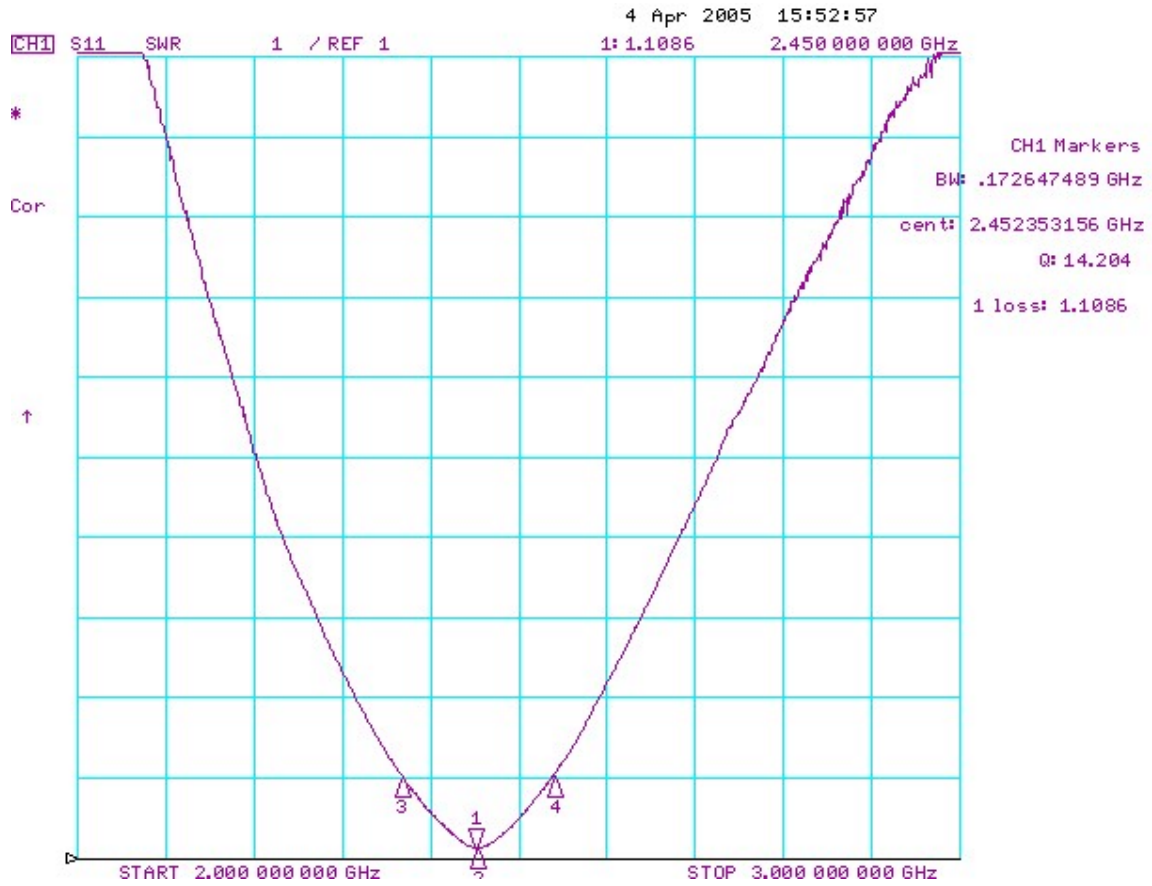

R&D	Print date 05/09/06					2005.4.4
	3216 Ceramic Chip Antenna for Bluetooth/WLAN Application			CAN4311712002453K		
Mars Liu	C.T.Lee			Page 5	sheet 190-5	A4
spec.doc	Yageo Taiwan					

6. The Definition of X-Y-Z Plane and Angle

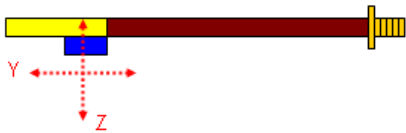
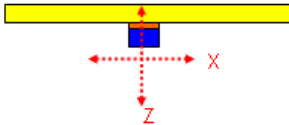
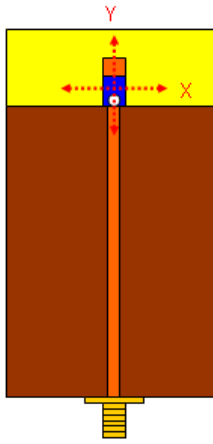

R&D	Print date 05/09/06							
	3216 Ceramic Chip Antenna for Bluetooth/WLAN Application					CAN4311712002453K		2005.4.4
Mars Liu	C.T.Lee			Page 6	sheet 190-6		A4	
spec.doc	Yageo Taiwan							

7. The Environment of Antenna Radiation Pattern
Anechoic Chamber Dimension=8(m) × 4(m) × 4(m)

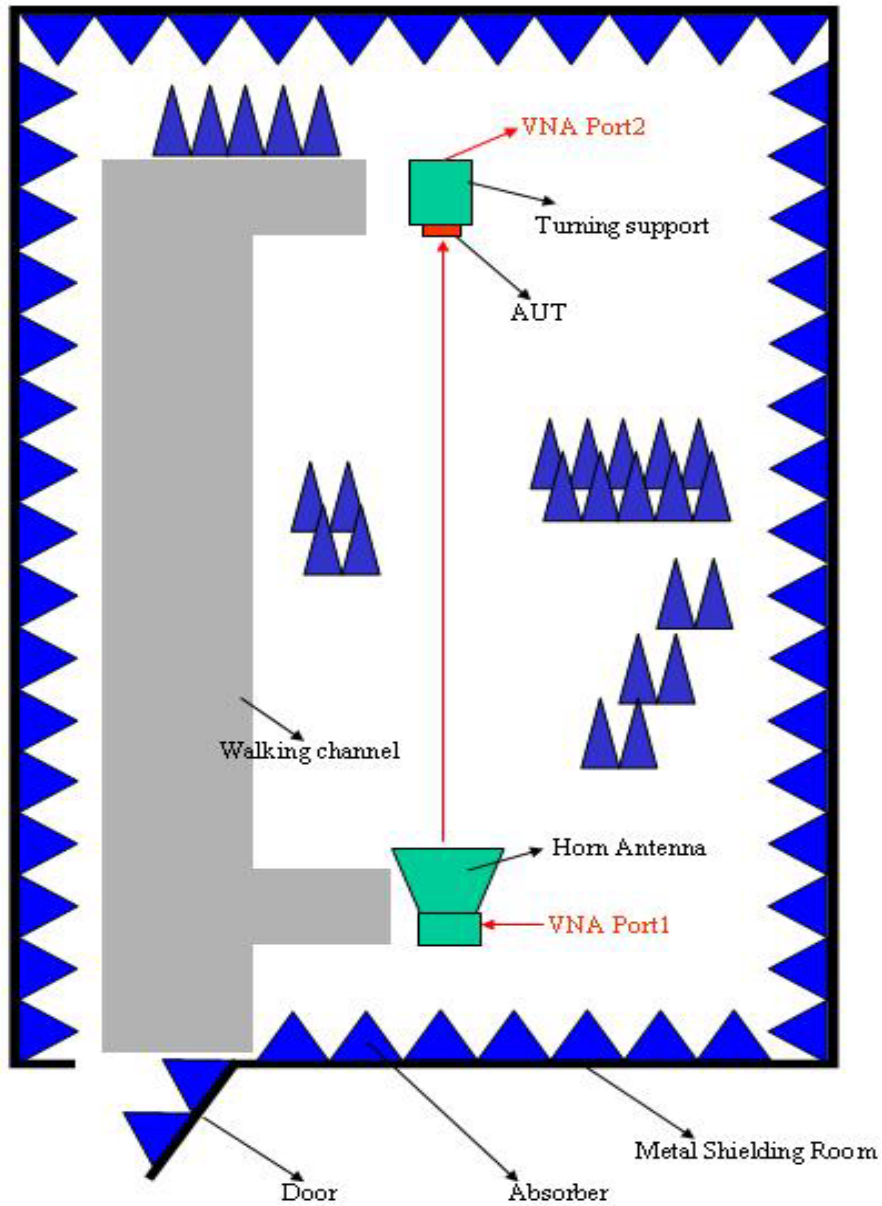

R&D	Print date 05/09/06					2005.4.4
	3216 Ceramic Chip Antenna for Bluetooth/WLAN Application		CAN4311712002453K			
Mars Liu	C.T.Lee		Page 7	sheet 190-7		A4
spec.doc	Yageo Taiwan					

8. Radiation Pattern

2450 MHz

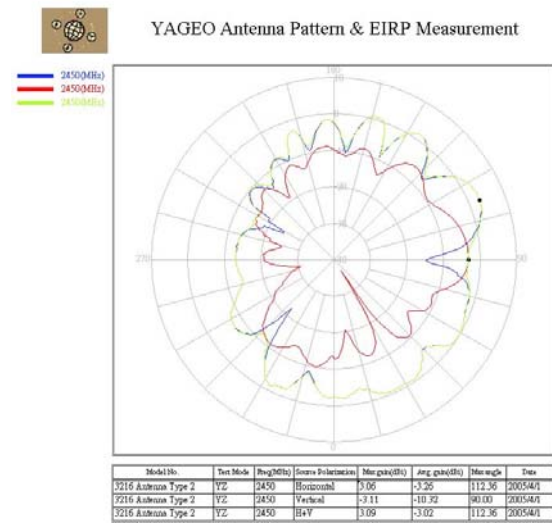
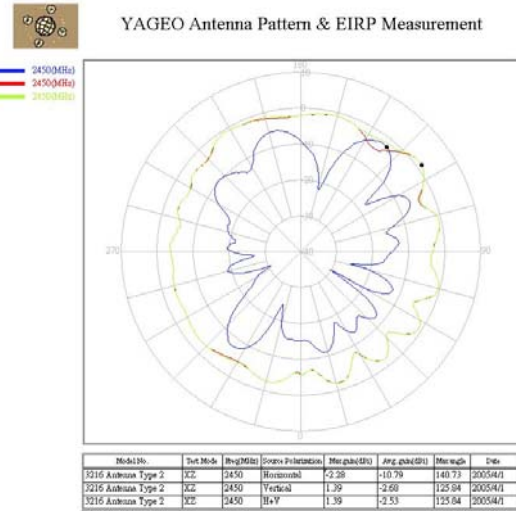
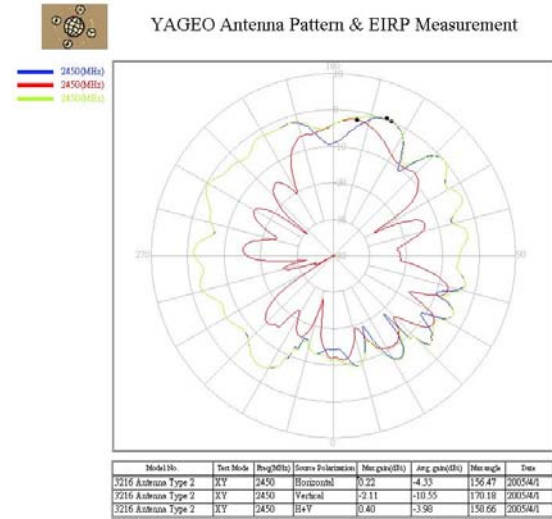

R&D	Print date 05/09/06							
	3216 Ceramic Chip Antenna for Bluetooth/WLAN Application					CAN4311712002453K		2005.4.4
Mars Liu	C.T.Lee			Page 8	sheet 190-8		A4	
spec.doc	Yageo Taiwan							

IEC 384-10/ CECC 32 100 CLAUSE	IEC 60068-2 TEST METHOD	TEST	PROCEDURE	REQUIREMENTS
4.4		Mounting	The antenna can be mounted on printed-circuit boards or ceramic substrates by applying wave soldering, reflow soldering (including vapour phase soldering) or conductive adhesive	No visible damage
4.5		Visual inspection and dimension check	Any applicable method using $\times 10$ magnification	In accordance with specification (chip off 4mm)
4.6.1		Antenna	Central Frequency at 20 °C	Standard test board in page 4
4.8		Adhesion	A force of 3 N applied for 10 s to the line joining the terminations and in a plane parallel to the substrate	No visible damage
4.9		Bond strength of plating on end face	Mounted in accordance with CECC 32 100, paragraph 4.4	No visible damage
			Conditions: bending 0.5 mm at a rate of 1mm/s, radius jig. 340 mm, 2mm warp on FR4 board of 90 mm length	No visible damage
4.10	20(Tb)	Resistance to soldering heat	260 \pm 5 °C for 10 \pm 0.5 s in a static solder bath	The terminations shall be well tinned after recovery and Central Freq. Change \pm 6%
		Resistance to leaching	260 \pm 5 °C for 30 \pm 1 s in a static solder bath	Using visual enlargement of $\times 10$, dissolution of the termination shall not exceed 10%

R&D	Print date 05/09/06						
	3216 Ceramic Chip Antenna for Bluetooth/WLAN Application			CAN4311712002453K			2005.4.4
Mars Liu	C.T.Lee			Page 9	sheet 190-9		A4
spec.doc	Yageo Taiwan						

IEC 384-10/ CECC 32 100 CLAUSE	IEC 60068-2 TEST METHOD	TEST	PROCEDURE	REQUIREMENTS
4.11	20(Ta)	Solderability	Zero hour test, and test after storage (20 to 24 months) in original atmosphere; un-mounted chips completely immersed for 2 ± 0.5 s in $235 \pm 5^\circ\text{C}$.	The termination must be well tinned, at least 75% is well tinned at termination
4.12	4(Na)	Rapid change of temperature	-25°C (30 minutes) to $+85^\circ\text{C}$ (30 minutes); 100 cycles	No visible damage Central Freq. Change $\pm 6\%$
4.14	3(Ca)	Damp heat	500 ± 12 hours at 60°C ; 90 to 95 % RH	No visible damage 2 hours recovery Central Freq. Change $\pm 6\%$
4.15		Endurance	500 ± 12 hours at 85°C ;	No visible damage 2 hours recovery Central Freq. Change $\pm 6\%$

R&D	Print date 05/09/06						
	3216 Ceramic Chip Antenna for Bluetooth/WLAN Application				CAN4311712002453K		2005.4.4
Mars Liu	C.T.Lee			Page 10	sheet 190-10		A4
spec.doc	Yageo Taiwan						

Ordering Information

The antennas may be ordered by using the Yageo ordering code. These code numbers can be determined by the following rules:

CAN 43 11 7 12 00 245 3K

CAN = Yageo Part No. for Antenna

Family Code

43 = Antenna

Packing Type Code

11 = 180 mm/ 7" reel , blister taping

Materials Code

7 = High Frequency Material

Size Code

11 = 3.2 * 2.5

12 = 3.2 * 1.6

13 = 2.5 * 2.0

14 = 2.0 * 1.2

15 = 1.6 * 0.8

Tolerance

00 = at least 200 MHz Impedance Bandwidth

Working Frequency

245 = 2.45 GHz

Packing Type Code

3K = 3000 pcs for tape

CAN4311712002453K (Clear Text Code Example)						
CAN43	11	7	12	00	245	3K
Product	Pacing tape code	Material Code	Size	Tolerance	Working frequency	Packing
CAN= Ceramic Antenna	11 = 180 mm/ 7" blister	7 = High frequency material	3.2*1.6 mm	At least 200MHz Impedence Bandwidth	245 = 2.45GHz	3= 3 Kpcs K=7" plastic F =13" plastic B = Bulk

R&D	Print date 05/09/06					
	3216 Ceramic Chip Antenna for Bluetooth/WLAN Application			CAN4311712002453K		2005.4.4
Mars Liu	C.T.Lee			Page 11	sheet 190-11	A4
spec.doc	Yageo Taiwan					

Taping Blister Tape

DIMENSION:

Serial no	Checking note	Index	Spec(mm)
1	Sprocket hole	Do	1.50±0.10
2	Pocket hole	D1	1.0±0.05
3	Distance sprocket hole/sprocket hole	Po	4.0±0.10
4	Distance pocket/pocket	P1	4.0±0.10
5	Distance sprocket hole/pocket	P2	2.0±0.05
6	Tape width	W	12.0±0.30
7	Distance sprocket hole/outside	E	1.75±0.10
8	Distance sprocket hole/pocket	F	5.50±0.05
9	Pocket length	Ao	1.47±0.20
10	Pocket length	Bo	3.4±0.20
11	Pocket depth	Ko	1.8±0.20
12	Thickness of tape	T	0.279±0.02
13	10x sprocket hole pitch	10Po	40.0±0.20

R&D	Print date 05/09/06						
	3216 Ceramic Chip Antenna for Bluetooth/WLAN Application				CAN4311712002453K		2005.4.4
Mars Liu	C.T.Lee			Page 12	sheet 190-12		A4
spec.doc	Yageo Taiwan						

7”(180mm) Reel Specifications

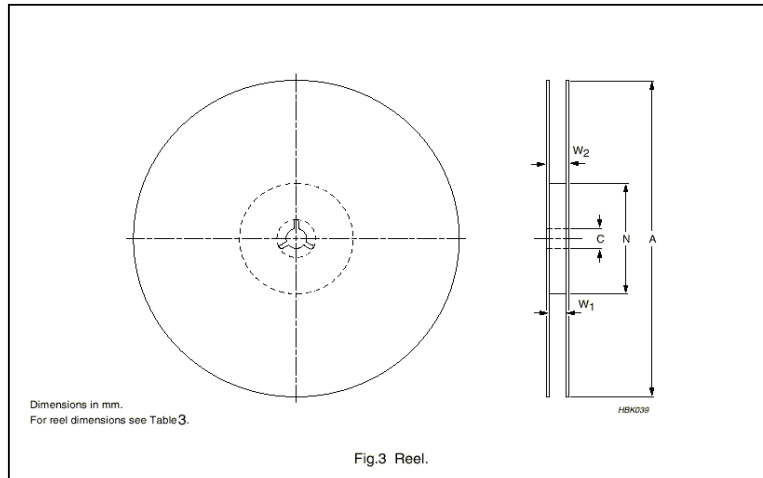

TAPE WEITH (mm)	A (mm)	N (mm)	C (mm)	W ₁ (mm)	W ₂ MAX. (mm)
12	180	60±1	13 ^{+0.50} / _{-0.20}	12.4 ^{+2.0} / _{-0.0}	18.4

Revision Control:

Revision	Date	Content	Remark
	4 th , April, 2005	New Issued	

R&D	Print date 05/09/06		
	3216 Ceramic Chip Antenna for Bluetooth/WLAN Application		CAN4311712002453K
			2005.4.4
Mars Liu	C.T.Lee		Page 13
spec.doc	Yageo Taiwan		sheet 190-13
			A4