

16-bit and 24-bit ADCs with Ultra-low-noise PGIA

Features

- Chopper-stabilized PGIA (Programmable Gain Instrumentation Amplifier, 1x to 64x)
6 nV/ $\sqrt{\text{Hz}}$ @ 0.1 Hz (No 1/f noise) at 64x
500 pA Input Current with Gains >1
- Delta-sigma Analog-to-digital Converter
Linearity Error: 0.0007% FS
Noise Free Resolution: Up to 23 bits
- Two- or Four-channel Differential MUX
- Scalable Input Span via Calibration
 ± 5 mV to differential ± 2.5 V
- Scalable V_{REF} Input: Up to Analog Supply
- Simple Three-wire Serial Interface
SPI™ and Microwire™ Compatible
Schmitt Trigger on Serial Clock (SCLK)
- R/W Calibration Registers Per Channel
- Selectable Word Rates: 6.25 to 3,840 Sps
- Selectable 50 or 60 Hz Rejection
- Power Supply Configurations
 $V_{A+} = +5$ V; $V_{A-} = 0$ V; $V_{D+} = +3$ V to +5 V
 $V_{A+} = +2.5$ V; $V_{A-} = -2.5$ V; $V_{D+} = +3$ V to +5 V
 $V_{A+} = +3$ V; $V_{A-} = -3$ V; $V_{D+} = +3$ V

General Description

The CS5531/32/33/34 are highly integrated $\Delta\Sigma$ Analog-to-Digital Converters (ADCs) which use charge-balance techniques to achieve 16-bit (CS5531/33) and 24-bit (CS5532/34) performance. The ADCs are optimized for measuring low-level unipolar or bipolar signals in weigh scale, process control, scientific, and medical applications.

To accommodate these applications, the ADCs come as either two-channel (CS5531/32) or four-channel (CS5533/34) devices and include a very low noise chopper-stabilized instrumentation amplifier (6 nV/ $\sqrt{\text{Hz}}$ @ 0.1 Hz) with selectable gains of 1x, 2x, 4x, 8x, 16x, 32x, and 64x. These ADCs also include a fourth order $\Delta\Sigma$ modulator followed by a digital filter which provides twenty selectable output word rates of 6.25, 7.5, 12.5, 15, 25, 30, 50, 60, 100, 120, 200, 240, 400, 480, 800, 960, 1600, 1920, 3200, and 3840 Sps (MCLK = 4.9152 MHz).

To ease communication between the ADCs and a microcontroller, the converters include a simple three-wire serial interface which is SPI and Microwire compatible with a Schmitt Trigger input on the serial clock (SCLK).

High dynamic range, programmable output rates, and flexible power supply options makes these ADCs ideal solutions for weigh scale and process control applications.

ORDERING INFORMATION

See page 48

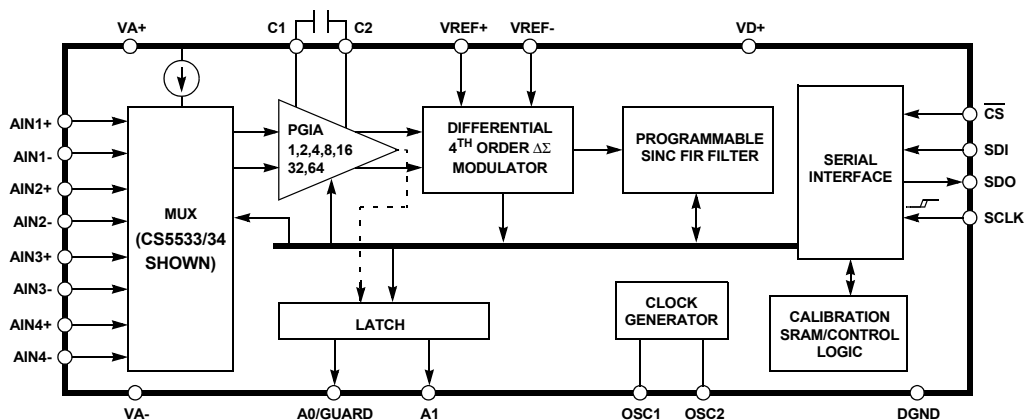

Preliminary Product Information

This document contains information for a new product. Cirrus Logic reserves the right to modify this product without notice.

TABLE OF CONTENTS

1. CHARACTERISTICS AND SPECIFICATIONS	4
ANALOG CHARACTERISTICS.....	4
TYPICAL RMS NOISE (NV), CS5531/32/33/34-AS	7
TYPICAL NOISE FREE RESOLUTION(BITS), CS5532/34-AS	7
TYPICAL RMS NOISE (NV), CS5532/34-BS	8
TYPICAL NOISE FREE RESOLUTION(BITS), CS5532/34-BS	8
5 V DIGITAL CHARACTERISTICS	9
3 V DIGITAL CHARACTERISTICS	9
DYNAMIC CHARACTERISTICS	10
ABSOLUTE MAXIMUM RATINGS	10
SWITCHING CHARACTERISTICS	11
2. GENERAL DESCRIPTION	13
2.1. Analog Input	13
2.1.1. Analog Input Span	14
2.1.2. Multiplexed Settling Limitations	14
2.1.3. Voltage Noise Density Performance	14
2.1.4. No Offset DAC	14
2.2. Overview of ADC Register Structure and Operating Modes	15
2.2.1. System Initialization	16
2.2.2. Command Register Quick Reference	18
2.2.3. Command Register Descriptions	19
2.2.4. Serial Port Interface	23
2.2.5. Reading/Writing On-Chip Registers	24
2.3. Configuration Register	24
2.3.1. Power Consumption	24
2.3.2. System Reset Sequence	24
2.3.3. Input Short	25
2.3.4. Guard Signal	25
2.3.5. Voltage Reference Select	25
2.3.6. Output Latch Pins	25
2.3.7. Offset and Gain Select	26
2.3.8. Filter Rate Select	26
2.3.9. Configuration Register Descriptions	27
2.4. Setting up the CSRs for a Measurement	28
2.4.1. Channel-Setup Register Descriptions	29
2.5. Calibration	31
2.5.1. Calibration Registers	31
2.5.2. Gain Register	31
2.5.3. Offset Register	31
2.5.4. Performing Calibrations	32
2.5.5. Self Calibration	32
2.5.6. System Calibration	33
2.5.7. Calibration Tips	33
2.5.8. Limitations in Calibration Range	34
2.6. Performing Conversions	34
2.6.1. Single Conversion Mode	34
2.6.2. Continuous Conversion Mode	35
2.6.3. Examples of Using CSRs to Perform Conversions and Calibrations	36
2.7. Using Multiple ADCs Synchronously	37
2.8. Conversion Output Coding	37
2.8.1. Conversion Data Output Descriptions	38
2.9. Digital Filter	39
2.10. Clock Generator	40
2.11. Power Supply Arrangements	40

2.12. Getting Started	44
2.13. PCB Layout	44
3. PIN DESCRIPTIONS	45
Clock Generator	45
Control Pins and Serial Data I/O	45
Measurement and Reference Inputs	46
Power Supply Connections	46
4. SPECIFICATION DEFINITIONS	47
5. ORDERING GUIDE	48
6. PACKAGE DRAWINGS	49

LIST OF FIGURES

Figure 1. SDI Write Timing (Not to Scale).....	12
Figure 2. SDO Read Timing (Not to Scale).....	12
Figure 3. Multiplexer Configuration	13
Figure 4. Input models for AIN+ and AIN- pins	14
Figure 5. Measured Voltage Noise Density.....	14
Figure 6. CS5531/32/33/34 Register Diagram.....	15
Figure 7. Command and Data Word Timing	23
Figure 8. Guard Signal Shielding Scheme	25
Figure 9. Input Reference Model when VRS = 1	26
Figure 10. Input Reference Model when VRS = 0	26
Figure 11. Self Calibration of Offset	33
Figure 12. Self Calibration of Gain	33
Figure 13. System Calibration of Offset	33
Figure 14. System Calibration of Gain	33
Figure 15. Synchronizing Multiple ADCs.....	37
Figure 16. Digital Filter Response (Word Rate = 60 Sps).....	39
Figure 17. 120 Sps Filter Magnitude Plot to 120 Hz	39
Figure 18. 120 Sps Filter Phase Plot to 120 Hz	39
Figure 19. Z-Transforms of Digital Filters.....	39
Figure 20. On-chip Oscillator Model.....	40
Figure 21. CS5532 Configured with a Single +5 V Supply	41
Figure 22. CS5532 Configured with ± 2.5 V Analog Supplies.....	42
Figure 23. CS5532 Configured with ± 3 V Analog Supplies.....	42
Figure 24. CS5532 Configured for Thermocouple Measurement	43
Figure 25. Bridge with Series Resistors.....	43

LIST OF TABLES

Table 1. Conversion Timing for Single Mode	35
Table 2. Conversion Timing for Continuous Mode.....	36
Table 3. Command Byte Pointer	36
Table 4. Output Coding for 16-bit CS5531 and CS5533.....	37
Table 5. Output Coding for 24-bit CS5532 and CS5534.....	38

1. CHARACTERISTICS AND SPECIFICATIONS

ANALOG CHARACTERISTICS (

VA+, VD+ = 5 V ±5%; VREF+ = 5 V; VA-, VREF-, DGND = 0 V; MCLK = 4.9152 MHz; OWR (Output Word Rate) = 60 Sps; Bipolar Mode; Gain = 32)

(See Notes 1 and 2.)

Parameter	CS5531-AS/CS5533-AS			Unit
	Min	Typ	Max	
Accuracy				
Linearity Error	-	±0.0015	±0.003	%FS
No Missing Codes	16	-	-	Bits
Bipolar Offset	-	±1	±2	LSB ₁₆
Unipolar Offset	-	±2	±4	LSB ₁₆
Offset Drift (Notes 3 and 4)	-	640/G + 5	-	nV/°C
Bipolar Full Scale Error	-	±8	±31	ppm
Unipolar Full Scale Error	-	±16	±62	ppm
Full Scale Drift (Note 4)	-	2	-	ppm/°C

Parameter	CS5532-AS/CS5534-AS			CS5532-BS/CS5534-BS			Unit
	Min	Typ	Max	Min	Typ	Max	
Accuracy							
Linearity Error	-	±0.0015	±0.003	-	±0.0007	±0.0015	%FS
No Missing Codes	24	-	-	24	-	-	Bits
Bipolar Offset	-	±16	±32	-	±16	±32	LSB ₂₄
Unipolar Offset	-	±32	±64	-	±32	±64	LSB ₂₄
Offset Drift (Notes 3 and 4)	-	640/G + 5	-	-	640/G + 5	-	nV/°C
Bipolar Full Scale Error	-	±8	±31	-	±8	±31	ppm
Unipolar Full Scale Error	-	±16	±62	-	±16	±62	ppm
Full Scale Drift (Note 4)	-	2	-	-	2	-	ppm/°C

- Notes:
1. Applies after system calibration at any temperature within -40 °C ~ +85 °C.
 2. Specifications guaranteed by design, characterization, and/or test. LSB is 16 bits for the CS5531/33 and LSB is 24 bits for the CS5532/34.
 3. This specification applies to the device only and does not include any effects by external parasitic thermocouples. The PGIA contributes 5 nV of offset drift, and the modulator contributes 640/G nV of offset drift, where G is the amplifier gain setting.
 4. Drift over specified temperature range after calibration at power-up at 25 °C.

ANALOG CHARACTERISTICS (Continued)

(See Notes 1 and 2.)

Parameter	Min	Typ	Max	Unit	
Analog Input					
Common Mode + Signal on AIN+ or AIN-Bipolar/Unipolar Mode					
Gain = 1	VA-	-	VA+	V	
Gain = 2, 4, 8, 16, 32, 64 (Note 5)	VA- + 0.7	-	VA+ - 1.7	V	
CVF Current on AIN+ or AIN-					
Gain = 1 (Note 6, 7)	-	50	-	nA	
Gain = 2, 4, 8, 16, 32, 64	-	1200	-	pA	
Input Current Noise					
Gain = 1	-	200	-	pA/√Hz	
Gain = 2, 4, 8, 16, 32, 64	-	1	-	pA/√Hz	
Input Leakage for Mux when Off (at 25 °C)	-	10	-	pA	
Off-Channel Mux Isolation	-	120	-	dB	
Open Circuit Detect Current	100	300	-	nA	
Common Mode Rejection					
dc, Gain = 1	-	90	-	dB	
dc, Gain = 64	-	130	-	dB	
50, 60 Hz	-	120	-	dB	
Input Capacitance	-	60	-	pF	
Guard Drive Output	-	20	-	μA	
Voltage Reference Input					
Range	(VREF+) - (VREF-)	1	2.5	(VA+)-(VA-)	V
CVF Current	(Note 6, 7)	-	50	-	nA
Common Mode Rejection					
dc	-	120	-	dB	
50, 60 Hz	-	120	-	dB	
Input Capacitance	11	-	22	pF	
System Calibration Specifications					
Full Scale Calibration Range	Bipolar/Unipolar Mode	3	-	110	%FS
Offset Calibration Range	Bipolar Mode	-100	-	100	%FS
Offset Calibration Range	Unipolar Mode	-90	-	90	%FS

Notes: 5. The voltage on the analog inputs is amplified by the PGIA, and becomes $V_{CM} \pm \text{Gain} \cdot (\text{AIN+} - \text{AIN-})/2$ at the differential outputs of the amplifier. In addition to the input common mode + signal requirements for the analog input pins, the differential outputs of the amplifier must remain between (VA- + 0.1 V) and (VA+ - 0.1 V) to avoid saturation of the output stage.

6. See the section of the data sheet which discusses input models.

7. Input current on AIN+ or AIN- (with Gain = 1), or VREF+ or VREF- may increase to 250 nA if operated within 50 mV of VA+ or VA-. This is due to the rough charge buffer being saturated under these conditions.

ANALOG CHARACTERISTICS (Continued)

(See Notes 1 and 2.)

Parameter		CS5531/32/33/34-AS			CS5532/34-BS			Unit
		Min	Typ	Max	Min	Typ	Max	
Power Supplies								
DC Power Supply Currents (Normal Mode)	I_{A+}, I_{A-}	-	7	9	-	13	15	mA
	I_{D+}	-	0.5	1	-	0.5	1	mA
Power Consumption	Normal Mode (Notes 8 and 9)	-	40	50	-	70	80	mW
	Standby	-	5	-	-	4	-	mW
	Sleep	-	500	-	-	500	-	μ W
Power Supply Rejection (Note 10)	dc Positive Supplies	-	115	-	-	115	-	dB
	dc Negative Supply	-	115	-	-	115	-	dB

8. All outputs unloaded. All input CMOS levels.
9. Power is specified when the instrumentation amplifier (Gain ≥ 2) is on. Analog supply current is reduced by approximately 1/2 when the instrumentation amplifier is off (Gain = 1).
10. Tested with 100 mV change on VA+ or VA-.

TYPICAL RMS NOISE (nV), CS5531/32/33/34-AS

(See notes 11, 12 and 13)

Output Word Rate (Sps)	-3 dB Filter Frequency (Hz)	Instrumentation Amplifier Gain						
		x64	x32	x16	x8	x4	x2	x1
7.5	1.94	17	17	19	26	42	79	155
15	3.88	24	25	27	36	59	111	218
30	7.75	34	35	39	51	84	157	308
60	15.5	48	49	54	72	118	222	436
120	31	68	70	77	102	167	314	616
240	62	115	160	276	527	1040	2070	4150
480	122	163	230	392	748	1480	2950	5890
960	230	229	321	554	1060	2090	4170	8340
1,920	390	344	523	946	1840	3650	7290	14600
3,840	780	1390	2710	5390	10800	21500	43000	86100

- Notes: 11. Wideband noise aliased into the baseband. Referred to the input. Typical values shown for 25 °C.
 12. For Peak-to-Peak Noise multiply by 6.6 for all ranges and output rates.
 13. Word rates and -3dB points with FRS = 0. When FRS = 1, word rates and -3dB points scale by 5/6.

TYPICAL NOISE FREE RESOLUTION(BITS), CS5532/34-AS (See Notes 14 and 15)

Output Word Rate (Sps)	-3 dB Filter Frequency (Hz)	Instrumentation Amplifier Gain						
		x64	x32	x16	x8	x4	x2	x1
7.5	1.94	19	20	21	22	22	22	22
15	3.88	19	20	21	21	21	22	22
30	7.75	18	19	20	21	21	21	21
60	15.5	18	19	20	20	20	21	21
120	31	17	18	19	20	20	20	20
240	62	16	17	17	17	17	17	17
480	122	16	17	17	17	17	17	17
960	230	15	16	16	16	16	16	16
1,920	390	15	15	15	15	15	15	15
3,840	780	13	13	13	13	13	13	13

14. Noise Free Resolution listed is for Bipolar operation, and is calculated as $\text{LOG}((\text{Input Span})/(6.6 \times \text{RMS Noise}))/\text{LOG}(2)$ rounded to the nearest bit. For Unipolar operation, the input span is 1/2 as large, so one bit is lost. The input span is calculated in the analog input span section of the data sheet. The Noise Free Resolution table is computed with a value of 1.0 in the gain register. Values other than 1.0 will scale the noise, and change the Noise Free Resolution accordingly.
15. “Noise Free Resolution” is not the same as “Effective Resolution”. Effective Resolution is based on the RMS noise value, while Noise Free Resolution is based on a peak-to-peak noise value specified as 6.6 times the RMS noise value. Effective Resolution is calculated as $\text{LOG}((\text{Input Span})/(\text{RMS Noise}))/\text{LOG}(2)$.

Specifications are subject to change without notice.

TYPICAL RMS NOISE (nV), CS5532/34-BS

(See notes 16, 17, 18 and 19)

Output Word Rate (Sps)	-3 dB Filter Frequency (Hz)	Instrumentation Amplifier Gain						
		x64	x32	x16	x8	x4	x2	x1
7.5	1.94	8.5	9	10	15	26	50	99
15	3.88	12	13	15	21	37	70	139
30	7.75	17	18	21	30	52	99	196
60	15.5	24	25	29	42	73	140	277
120	31	34	36	42	59	103	198	392
240	62	80	136	260	514	1020	2050	4090
480	122	113	194	369	730	1450	2900	5810
960	230	159	274	523	1030	2060	4110	8230
1,920	390	260	470	912	1810	3620	7230	14500
3,840	780	1360	2690	5380	10800	21500	43000	86000

Notes: 16. The -B devices provide the best noise specifications.

17. Wideband noise aliased into the baseband. Referred to the input. Typical values shown for 25 °C.

18. For Peak-to-Peak Noise multiply by 6.6 for all ranges and output rates.

19. Word rates and -3dB points with FRS = 0. When FRS = 1, word rates and -3dB points scale by 5/6.

TYPICAL NOISE FREE RESOLUTION(BITS), CS5532/34-BS

(See Notes 20 and 21)

Output Word Rate (Sps)	-3 dB Filter Frequency (Hz)	Instrumentation Amplifier Gain						
		x64	x32	x16	x8	x4	x2	x1
7.5	1.94	20	21	22	23	23	23	23
15	3.88	20	21	22	22	22	22	22
30	7.75	19	20	21	22	22	22	22
60	15.5	19	20	21	21	21	21	21
120	31	18	19	20	21	21	21	21
240	62	17	17	18	18	18	18	18
480	122	17	17	17	17	17	17	17
960	230	16	16	17	17	17	17	17
1,920	390	16	16	16	16	16	16	16
3,840	780	13	13	13	13	13	13	13

 20. Noise Free Resolution listed is for Bipolar operation, and is calculated as $\text{LOG}((\text{Input Span})/(6.6 \times \text{RMS Noise}))/\text{LOG}(2)$ rounded to the nearest bit. For Unipolar operation, the input span is 1/2 as large, so one bit is lost. The input span is calculated in the analog input span section of the data sheet. The Noise Free Resolution table is computed with a value of 1.0 in the gain register. Values other than 1.0 will scale the noise, and change the Noise Free Resolution accordingly.

 21. "Noise Free Resolution" is not the same as "Effective Resolution". Effective Resolution is based on the RMS noise value, while Noise Free Resolution is based on a peak-to-peak noise value specified as 6.6 times the RMS noise value. Effective Resolution is calculated as $\text{LOG}((\text{Input Span})/(\text{RMS Noise}))/\text{LOG}(2)$.

Specifications are subject to change without notice.

5 V DIGITAL CHARACTERISTICS (V_{A+} , $V_{D+} = 5\text{ V} \pm 5\%$; V_{A-} , $DGND = 0\text{ V}$;
See Notes 2 and 22.)

Parameter	Symbol	Min	Typ	Max	Unit
High-Level Input Voltage All Pins Except SCLK SCLK	V_{IH}	0.6 V_{D+} (V_{D+}) - 0.45	- -	V_{D+} V_{D+}	V
Low-Level Input Voltage All Pins Except SCLK SCLK	V_{IL}	0.0 0.0	-	0.8 0.6	V
High-Level Output Voltage A0 and A1, $I_{out} = -1.0\text{ mA}$ SDO, $I_{out} = -5.0\text{ mA}$	V_{OH}	(V_{A+}) - 1.0 (V_{D+}) - 1.0	-	-	V
Low-Level Output Voltage A0 and A1, $I_{out} = 1.0\text{ mA}$ SDO, $I_{out} = 5.0\text{ mA}$	V_{OL}	-	-	(V_{A-}) + 0.4 0.4	V
Input Leakage Current	I_{in}	-	± 1	± 10	μA
SDO 3-State Leakage Current	I_{OZ}	-	-	± 10	μA
Digital Output Pin Capacitance	C_{out}	-	9	-	pF

3 V DIGITAL CHARACTERISTICS ($T_A = 25\text{ }^\circ\text{C}$; $V_{A+} = 5\text{ V} \pm 5\%$; $V_{D+} = 3.0\text{ V} \pm 10\%$; V_{A-} , $DGND = 0\text{ V}$;
See Notes 2 and 22.)

Parameter	Symbol	Min	Typ	Max	Unit
High-Level Input Voltage All Pins Except SCLK SCLK	V_{IH}	0.6 V_{D+} (V_{D+}) - 0.45	-	V_{D+} V_{D+}	V
Low-Level Input Voltage All Pins Except SCLK SCLK	V_{IL}	0.0 0.0	-	0.8 0.6	V
High-Level Output Voltage A0 and A1, $I_{out} = -1.0\text{ mA}$ SDO, $I_{out} = -5.0\text{ mA}$	V_{OH}	(V_{A+}) - 1.0 (V_{D+}) - 1.0	-	-	V
Low-Level Output Voltage A0 and A1, $I_{out} = 1.0\text{ mA}$ SDO, $I_{out} = 5.0\text{ mA}$	V_{OL}	-	-	(V_{A-}) + 0.4 0.4	V
Input Leakage Current	I_{in}	-	± 1	± 10	μA
SDO 3-State Leakage Current	I_{OZ}	-	-	± 10	μA
Digital Output Pin Capacitance	C_{out}	-	9	-	pF

22. All measurements performed under static conditions.

DYNAMIC CHARACTERISTICS

Parameter	Symbol	Ratio	Unit
Modulator Sampling Rate	f_s	MCLK/16	Sps
Filter Settling Time to 1/2 LSB (Full Scale Step Input)	Single Conversion mode (Notes 23, 24, and 25)	$1/OWR_{SC}$	s
	Continuous Conversion mode, $OWR < 3200$ Sps	$5/OWR_{Sinc5} + 3/OWR$	s
	Continuous Conversion mode, $OWR \geq 3200$ Sps	$5/OWR$	s

23. The ADCs use a Sinc⁵ filter for the 3200 Sps and 3840 Sps output word rate (OWR) and a Sinc⁵ filter followed by a Sinc³ filter for the other OWRs. OWR_{Sinc5} refers to the 3200 Sps (FRS = 1) or 3840 Sps (FRS = 0) word rate associated with the Sinc⁵ filter.
24. The single conversion mode only outputs fully settled conversions. See Table 1 for more details about single conversion mode timing. OWR_{SC} is used here to designate the different conversion time associated with single conversions.
25. The continuous conversion mode outputs every conversion. This means that the filter's settling time with a full scale step input in the continuous conversion mode is dictated by the OWR.

ABSOLUTE MAXIMUM RATINGS

(DGND = 0 V; See Note 26.)

Parameter	Symbol	Min	Typ	Max	Unit	
DC Power Supplies (Notes 27 and 28)	Positive Digital	VD+	-0.3	-	+6.0	V
	Positive Analog	VA+	-0.3	-	+6.0	V
	Negative Analog	VA-	+0.3	-	-3.75	V
Input Current, Any Pin Except Supplies (Notes 29 and 30)	I_{IN}	-	-	±10	mA	
Output Current	I_{OUT}	-	-	±25	mA	
Power Dissipation (Note 31)	PDN	-	-	500	mW	
Analog Input Voltage	VREF pins	V_{INR}	(VA-) -0.3	-	(VA+) + 0.3	V
	AIN Pins	V_{INA}	(VA-) -0.3	-	(VA+) + 0.3	V
Digital Input Voltage	V_{IND}	-0.3	-	(VD+) + 0.3	V	
Ambient Operating Temperature	T_A	-40	-	85	°C	
Storage Temperature	T_{stg}	-65	-	150	°C	

Notes: 26. All voltages with respect to ground.

27. VA+ and VA- must satisfy $\{(VA+) - (VA-)\} \leq +6.6$ V.

28. VD+ and VA- must satisfy $\{(VD+) - (VA-)\} \leq +7.5$ V.

29. Applies to all pins including continuous overvoltage conditions at the analog input (AIN) pins.

30. Transient current of up to 100 mA will not cause SCR latch-up. Maximum input current for a power supply pin is ±50 mA.

31. Total power dissipation, including all input currents and output currents.

WARNING: Operation at or beyond these limits may result in permanent damage to the device. Normal operation is not guaranteed at these extremes.

SWITCHING CHARACTERISTICS

(VA+ = 2.5 V or 5 V ±5%; VA- = -2.5V±5% or 0 V; VD+ = 3.0 V ±10% or 5 V ±5%; DGND = 0 V; Levels: Logic 0 = 0 V, Logic 1 = VD+; C_L = 50 pF; See Figures 1 and 2.)

Parameter	Symbol	Min	Typ	Max	Unit
Master Clock Frequency (Note 32) External Clock or Crystal Oscillator	MCLK	1	4.9152	5	MHz
Master Clock Duty Cycle		40	-	60	%
Rise Times (Note 33) Any Digital Input Except SCLK SCLK Any Digital Output	t _{rise}	- - -	- - 50	1.0 100 -	μs μs ns
Fall Times (Note 33) Any Digital Input Except SCLK SCLK Any Digital Output	t _{fall}	- - -	- - 50	1.0 100 -	μs μs ns
Start-up					
Oscillator Start-up Time XTAL = 4.9152 MHz (Note 34)	t _{ost}	-	20	-	ms
Serial Port Timing					
Serial Clock Frequency	SCLK	0	-	2	MHz
Serial Clock Pulse Width High	t ₁	250	-	-	ns
Pulse Width Low	t ₂	250	-	-	ns
SDI Write Timing					
$\overline{\text{CS}}$ Enable to Valid Latch Clock	t ₃	50	-	-	ns
Data Set-up Time prior to SCLK rising	t ₄	50	-	-	ns
Data Hold Time After SCLK Rising	t ₅	100	-	-	ns
SCLK Falling Prior to $\overline{\text{CS}}$ Disable	t ₆	100	-	-	ns
SDO Read Timing					
$\overline{\text{CS}}$ to Data Valid	t ₇	-	-	150	ns
SCLK Falling to New Data Bit	t ₈	-	-	150	ns
$\overline{\text{CS}}$ Rising to SDO Hi-Z	t ₉	-	-	150	ns

- Notes: 32. Device parameters are specified with a 4.9152 MHz clock.
 33. Specified using 10% and 90% points on waveform of interest. Output loaded with 50 pF.
 34. Oscillator start-up time varies with crystal parameters. This specification does not apply when using an external clock source.

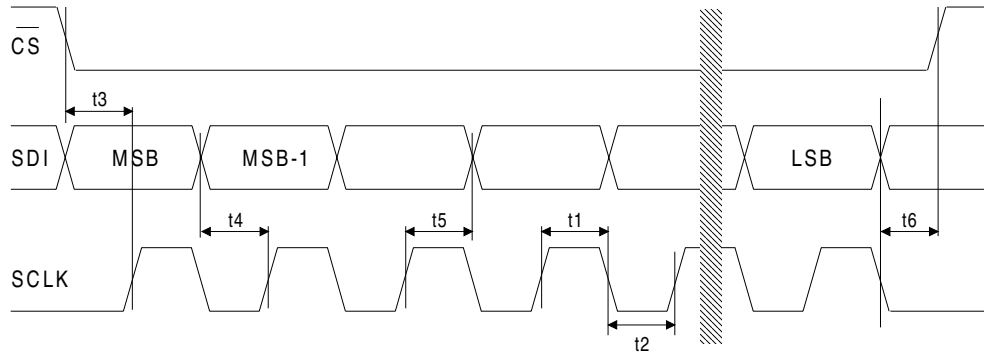

Figure 1. SDI Write Timing (Not to Scale)

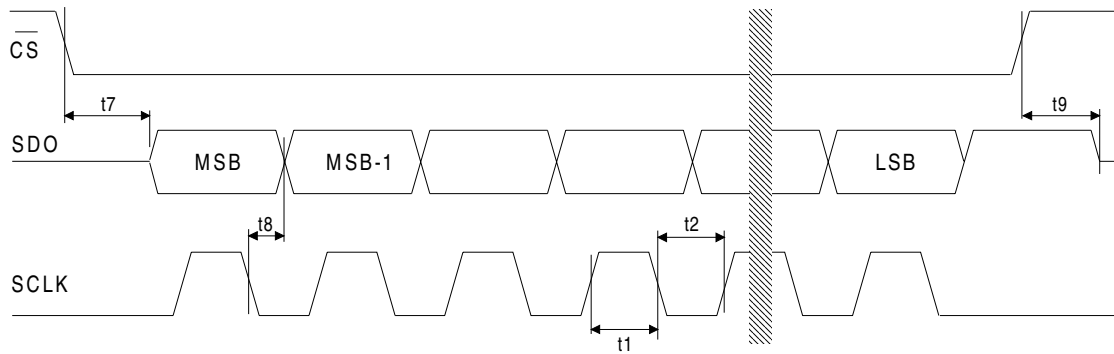

Figure 2. SDO Read Timing (Not to Scale)

2. GENERAL DESCRIPTION

The CS5531/32/33/34 are highly integrated $\Delta\Sigma$ Analog-to-Digital Converters (ADCs) which use charge-balance techniques to achieve 16-bit (CS5531/33) and 24-bit (CS5532/34) performance. The ADCs are optimized for measuring low-level unipolar or bipolar signals in weigh scale, process control, scientific, and medical applications.

To accommodate these applications, the ADCs come as either two-channel (CS5531/32) or four-channel (CS5533/34) devices and include a very low noise chopper-stabilized programmable gain instrumentation amplifier (PGIA, $6 \text{ nV}/\sqrt{\text{Hz}}$ @ 0.1 Hz) with selectable gains of $1\times$, $2\times$, $4\times$, $8\times$, $16\times$, $32\times$, and $64\times$. These ADCs also include a fourth order $\Delta\Sigma$ modulator followed by a digital filter which provides twenty selectable output word rates of 6.25, 7.5, 12.5, 15, 25, 30, 50, 60, 100, 120, 200, 240, 400, 480, 800, 960, 1600, 1920, 3200, and 3840 Samples per second (MCLK = 4.9152 MHz).

To ease communication between the ADCs and a micro-controller, the converters include a simple

three-wire serial interface which is SPI and Microwire compatible with a Schmitt Trigger input on the serial clock (SCLK).

2.1. Analog Input

Figure 3 illustrates a block diagram of the CS5531/32/33/34. The front end consists of a multiplexer, a unity gain coarse/fine charge input buffer, and a programmable gain chopper-stabilized instrumentation amplifier. The unity gain buffer is activated any time conversions are performed with a gain of one and the instrumentation amplifier is activated any time conversions are performed with gain settings greater than one.

The unity gain buffer is designed to accommodate rail to rail input signals. The common-mode plus signal range for the unity gain buffer amplifier is VA- to VA+. Typical CVF (sampling) current for the unity gain buffer amplifier is about 50 nA (MCLK = 4.9152 MHz, see Figure 4).

The instrumentation amplifier is chopper stabilized and operates with a chop clock frequency of

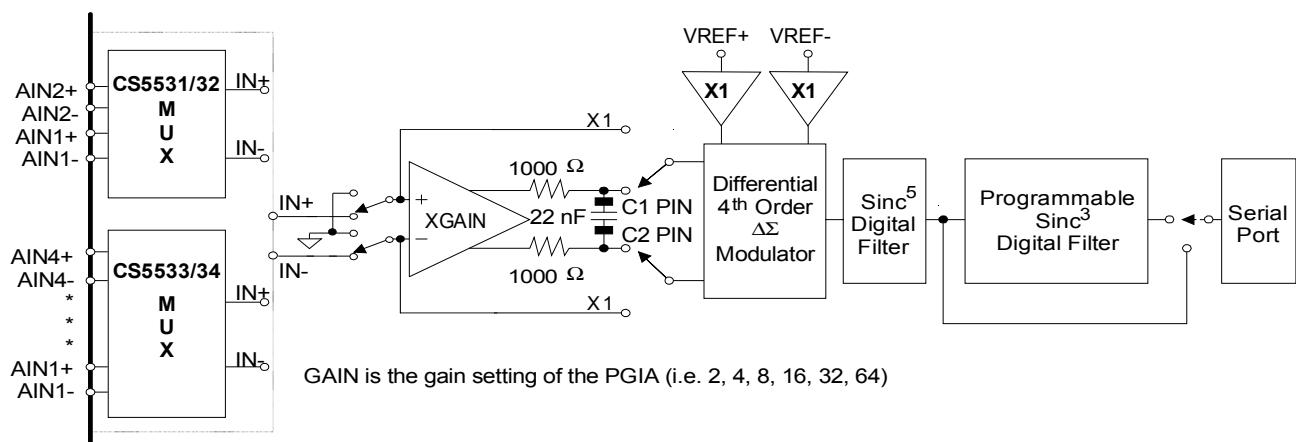

Figure 3. Multiplexer Configuration

MCLK/128. The CVF (sampling) current into the instrumentation amplifier is typically 1200 pA over -40°C to $+85^{\circ}\text{C}$ (MCLK=4.9152 MHz). The common-mode plus signal range of the instrumentation amplifier is (VA-) + 0.7 V to (VA+) - 1.7 V.

Figure 4 illustrates the input models for the amplifiers. The dynamic input current for each of the pins can be determined from the models shown.

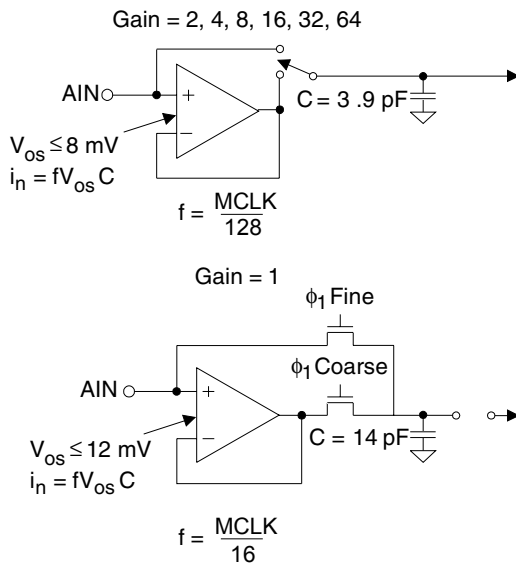

Figure 4. Input models for AIN+ and AIN- pins

Note: The C=3.9pF and C = 14pF capacitors are for input current modeling only. For physical input capacitance see 'Input Capacitance' specification under *Analog Characteristics*.

2.1.1. Analog Input Span

The full scale input signal that the converter can digitize is a function of the gain setting and the reference voltage connected between the VREF+ and VREF- pins. The full scale input span of the converter is $((VREF+) - (VREF-))/(G \times A)$, where G is the gain of the amplifier and A is 2 for VRS = 0, or A is 1 for VRS = 1. VRS is the Voltage Reference Select bit, and must be set according to the differential volt-

age applied to the VREF+ and VREF- pins on the part. See section 2.3.5 for more details.

After reset, the unity gain buffer is engaged. With a 2.5V reference this would make the full scale input range default to 2.5 V. By activating the instrumentation amplifier (i.e. a gain setting other than 1) and using a gain setting of 32, the full scale input range can quickly be set to 2.5/32 or about 78 mV. Note that these input ranges assume the calibration registers are set to their default values (i.e. Gain = 1.0 and Offset = 0.0).

2.1.2. Multiplexed Settling Limitations

The settling performance of the CS5531/32/33/34 in multiplexed applications is affected by the single-pole low-pass filter which follows the instrumentation amplifier (see Figure 3). To achieve data sheet settling and linearity specifications, it is recommended that a 22 nF C0G capacitor be used. Capacitors as low as 10 nF or X7R type capacitors can also be used with some minor increase in distortion for AC signals.

2.1.3. Voltage Noise Density Performance

Figure 5 illustrates the measured voltage noise density versus frequency from 0.01 Hz to 10 Hz of a CS5532-BS. The device was powered with ± 2.5 V supplies, using 120 Sps OWR, the 64x gain range, bipolar mode, and with the input short bit enabled.

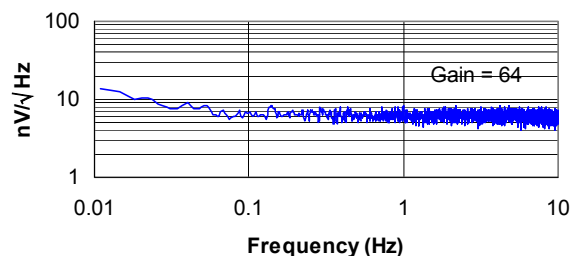

Figure 5. Measured Voltage Noise Density

2.1.4. No Offset DAC

An offset DAC was not included in the CS553X family because the high dynamic range of the con-

verter eliminates the need for one. The offset register can be manipulated by the user to mimic the function of a DAC if desired.

2.2. Overview of ADC Register Structure and Operating Modes

The CS5531/32/33/34 ADCs have an on-chip controller, which includes a number of user-accessible registers. The registers are used to hold offset and gain calibration results, configure the chip's operating modes, hold conversion instructions, and to store conversion data words. Figure 6 depicts a block diagram of the on-chip controller's internal registers.

Each of the converters has 32-bit registers to function as offset and gain calibration registers for each channel. The converters with two channels have two offset and two gain calibration registers, the converters with four channels have four offset and four gain calibration registers. These registers hold calibration results. The contents of these registers

can be read or written by the user. This allows calibration data to be off-loaded into an external EEPROM. The user can also manipulate the contents of these registers to modify the offset or the gain slope of the converter.

The converters include a 32-bit configuration register which is used for setting options such as the power down modes, resetting the converter, shorting the analog inputs, and enabling diagnostic test bits like the guard signal.

A group of registers, called Channel Setup Registers, are used to hold pre-loaded conversion instructions. Each channel setup register is 32 bits long, and holds two 16-bit conversion instructions referred to as Setups. Upon power up, these registers can be initialized by the system microcontroller with conversion instructions. The user can then instruct the converter to perform single or multiple conversions or calibrations with the converter in the mode defined by one of these Setups.

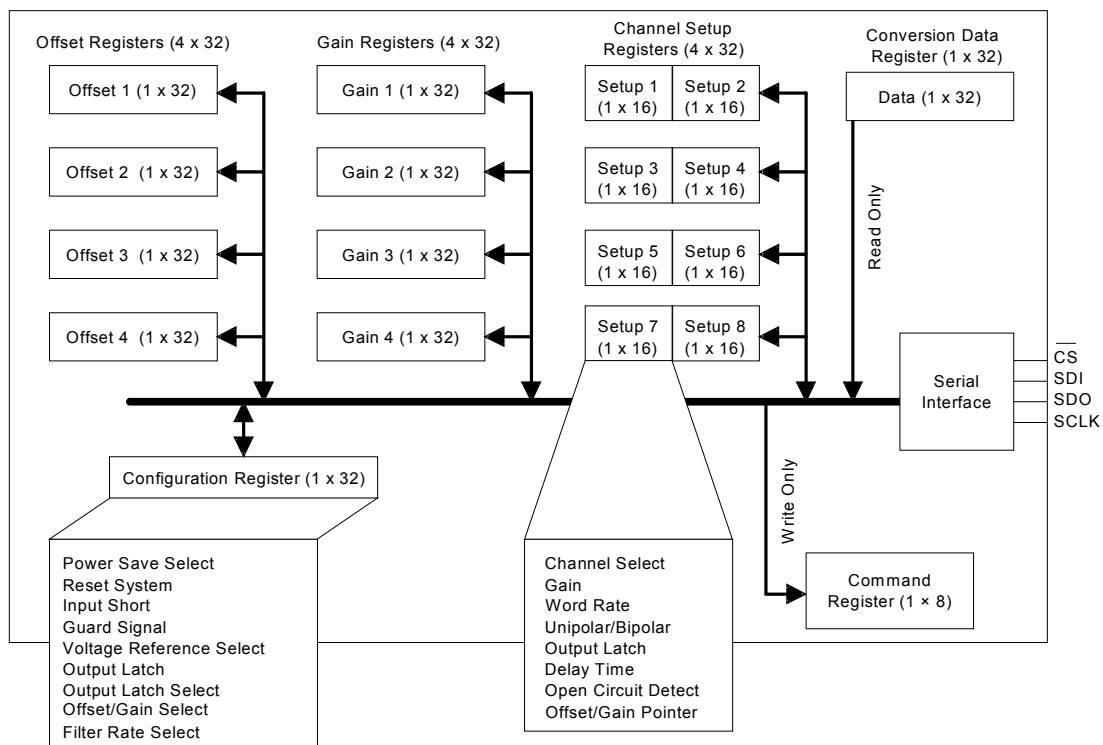

Figure 6. CS5531/32/33/34 Register Diagram

Using the single conversion mode, an 8-bit command word can be written into the serial port. The command includes pointer bits which ‘point’ to a 16-bit command in one of the Channel Setup Registers which is to be executed. The 16-bit Setups can be programmed to perform a conversion on any of the input channels of the converter. More than one of the 16-bit Setups can be used for the same analog input channel. This allows the user to convert on the same signal with either a different conversion speed, a different gain range, or any of the other options available in the channel setup registers. Alternately, the user can set up the registers to perform different conversion conditions on each of the input channels.

The ADCs also include continuous conversion capability. The ADCs can be instructed to continuously convert, referencing one 16-bit command Setup. In the continuous conversions mode, the conversion data words are loaded into a shift register. The converter issues a flag on the SDO pin when a conversion cycle is completed so the user can read the register, if need be. See the section on Performing Conversions for more details.

The following pages document how to initialize the converter, perform offset and gain calibrations, and how to configure the converter for the various conversion modes. Each of the bits of the configuration register and of the Channel Setup Registers is described. A list of examples follows the description section. Also the *Command Register Quick Reference* can be used to decode all valid commands (the first 8-bits into the serial port).

2.2.1. System Initialization

The CS5531/32/33/34 provide no power-on-reset function. To initialize the ADCs, the user must perform a software reset by resetting the ADC’s serial port with the Serial Port Initialization sequence. This sequence resets the serial port to the command mode and is accomplished by transmitting at least 15 SYNC1 command bytes (0xFF hexadecimal),

followed by one SYNC0 command (0xFE hexadecimal). Note that this sequence can be initiated at anytime to reinitialize the serial port. To complete the system initialization sequence, the user must also perform a system reset sequence which is as follows: Write a logic 1 into the RS bit of the configuration register. This will reset the calibration registers and other logic (but not the serial port). A valid reset will set the RV bit in the configuration register to a logic 1. After writing the RS bit to a logic 1, wait 20 microseconds, then write the RS bit back to logic 0. While this involves writing an entire word into the configuration register, the RV bit is a read only bit, therefore a write to the configuration register will not overwrite the RV bit. After clearing the RS bit back to logic 0, read the configuration register to check the state of the RV bit as this indicates that a valid reset occurred. Reading the configuration register clears the RV bit back to logic 0.

Completing the reset cycle initializes the on-chip registers to the following states:

Configuration Register:	00000000(H)
Offset Registers:	00000000(H)
Gain Registers:	01000000(H)
Channel Setup Registers:	00000000(H)

Note: Previous datasheets stated that the RS bit would clear itself back to logic 0 and therefore the user was not required to write the RS bit back to logic 0. The current data sheet instruction that requires the user to write into the configuration register to clear the RS bit has been added to insure that the RS bit is cleared. Characterization across multiple lots of silicon has indicated some chips do not automatically reset the RS bit to logic 0 in the configuration register, although the reset function is completed. This occurs only on small number of chips when the VA- supply is negative with respect to DGND. This has not caused an operational issue for customers because their start-up sequence includes writing a word (with RS=0) into the configuration register after performing a

reset. The change in the reset sequence to include writing the RS bit back to 0 insures the clearing of the RS bit in the event that a user does not write into the configuration register after the RS bit has been set.

The RV bit in the Configuration Register is set to indicate a valid reset has occurred. The RS bit should be written back to logic “0” to complete the reset cycle. After a system initialization or reset,

the on-chip controller is initialized into command mode where it waits for a valid command (the first 8-bits written into the serial port are shifted into the command register). Once a valid command is received and decoded, the byte instructs the converter to either acquire data from or transfer data to an internal register(s), or perform a conversion or a calibration. The *Command Register Descriptions* section can be used to decode all valid commands.

2.2.2. Command Register Quick Reference

D7(MSB)	D6	D5	D4	D3	D2	D1	D0
0	ARA	CS1	CS0	R/W	RSB2	RSB1	RSB0

BIT	NAME	VALUE	FUNCTION
D7	Command Bit, C	0	Must be logic 0 for these commands.
		1	These commands are invalid if this bit is logic 1.
D6	Access Registers as Arrays, ARA	0	Ignore this function.
		1	Access the respective registers, offset, gain, or channel-setup, as an array of registers. The particular registers accessed are determined by the RS bits. The registers are accessed MSB first with physical channel 0 accessed first followed by physical channel 1 next and so forth.
D5-D4	Channel Select Bits, CS1-CS0	00	CS1-CS0 provide the address of one of the two (four for CS5533/34) physical input channels. These bits are also used to access the calibration registers associated with the respective physical input channel. Note that these bits are ignored when reading data register.
		01	
		10	
		11	
D3	Read/Write, R/W	0	Write to selected register.
		1	Read from selected register.
D2-D0	Register Select Bit, RSB3-RSB0	000	Reserved
		001	Offset Register
		010	Gain Register
		011	Configuration Register
		101	Channel-Setup Registers
		110	Reserved
		111	Reserved

D7(MSB)	D6	D5	D4	D3	D2	D1	D0
1	MC	CSRP2	CSRP1	CSRP0	CC2	CC1	CC0

BIT	NAME	VALUE	FUNCTION
D7	Command Bit, C	0	These commands are invalid if this bit is logic 0.
		1	Must be logic 1 for these commands.
D6	Multiple Conversions, MC	0	Perform fully settled single conversions.
		1	Perform conversions continuously.
D5-D3	Channel-Setup Register Pointer Bits, CSRP	000	These bits are used as pointers to the Channel-Setup registers. Either a single conversion or continuous conversions are performed on the channel setup register pointed to by these bits.
		...	
		111	
D2-D0	Conversion/Calibration Bits, CC2-CC0	000	Normal Conversion
		001	Self-Offset Calibration
		010	Self-Gain Calibration
		011	Reserved
		100	Reserved
		101	System-Offset Calibration
		110	System-Gain Calibration
		111	Reserved

2.2.3. Command Register Descriptions

READ/WRITE ALL OFFSET CALIBRATION REGISTERS

D7(MSB)	D6	D5	D4	D3	D2	D1	D0
0	1	0	0	R/W	0	0	1

Function: These commands are used to access the offset registers as arrays.

R/W (Read/Write)

- 0 Write to selected registers.
- 1 Read from selected registers.

READ/WRITE ALL GAIN CALIBRATION REGISTERS

D7(MSB)	D6	D5	D4	D3	D2	D1	D0
0	1	0	0	R/W	0	1	0

Function: These commands are used to access the gain registers as arrays.

R/W (Read/Write)

- 0 Write to selected registers.
- 1 Read from selected registers.

READ/WRITE ALL CHANNEL-SETUP REGISTERS

D7(MSB)	D6	D5	D4	D3	D2	D1	D0
0	1	0	0	R/W	1	0	1

Function: These commands are used to access the channel-setup registers as arrays.

R/W (Read/Write)

- 0 Write to selected registers.
- 1 Read from selected registers.

READ/WRITE INDIVIDUAL OFFSET REGISTER

D7(MSB)	D6	D5	D4	D3	D2	D1	D0
0	0	CS1	CS0	R/W	0	0	1

Function: These commands are used to access each offset register separately. CS1 - CS0 decode the registers accessed.

R/W (Read/Write)

- 0 Write to selected register.
- 1 Read from selected register.

CS[1:0] (Channel Select Bits)

- 00 Offset Register 1 (All devices)
- 01 Offset Register 2 (All devices)
- 10 Offset Register 3 (CS5533/34 only)
- 11 Offset Register 4 (CS5533/34 only)

READ/WRITE INDIVIDUAL GAIN REGISTER

D7(MSB)	D6	D5	D4	D3	D2	D1	D0
0	0	CS1	CS0	R/W	0	1	0

Function: These commands are used to access each gain register separately. CS1 - CS0 decode the registers accessed.

R/W (Read/Write)

- 0 Write to selected register.
- 1 Read from selected register.

CS[1:0] (Channel Select Bits)

- 00 Gain Register 1 (All devices)
- 01 Gain Register 2 (All devices)
- 10 Gain Register 3 (CS5533/34 only)
- 11 Gain Register 4 (CS5533/34 only)

READ/WRITE INDIVIDUAL CHANNEL-SETUP REGISTER

D7(MSB)	D6	D5	D4	D3	D2	D1	D0
0	0	CS1	CS0	R/W	1	0	1

Function: These commands are used to access each channel-setup register separately. CS1 - CS0 decode the registers accessed.

R/W (Read/Write)

- 0 Write to selected register.
- 1 Read from selected register.

CS[1:0] (Channel Select Bits)

- 00 Channel-Setup Register 1 (All devices)
- 01 Channel-Setup Register 2 (All devices)
- 10 Channel-Setup Register 3 (All devices)
- 11 Channel-Setup Register 4 (All devices)

READ/WRITE CONFIGURATION REGISTER

D7(MSB)	D6	D5	D4	D3	D2	D1	D0
0	0	0	0	R/W	0	1	1

Function: These commands are used to read from or write to the configuration register.

R/W (Read/Write)

- 0 Write to selected register.
- 1 Read from selected register.

PERFORM CONVERSION

D7(MSB)	D6	D5	D4	D3	D2	D1	D0
1	MC	CSRP2	CSRP1	CSRP0	0	0	0

Function: These commands instruct the ADC to perform either a single, fully-settled conversion or continuous conversions on the physical input channel pointed to by the pointer bits (CSRP2 - CRSP0) in the channel-setup register.

MC (Multiple Conversions)

- 0 Perform a single conversion.
- 1 Perform continuous conversions.

CSRP [2:0] (Channel Setup Register Pointer Bits)

- 000 Setup 1 (All devices)
- 001 Setup 2 (All devices)
- 010 Setup 3 (All devices)
- 011 Setup 4 (All devices)
- 100 Setup 5 (All devices)
- 101 Setup 6 (All devices)
- 110 Setup 7 (All devices)
- 111 Setup 8 (All devices)

PERFORM CALIBRATION

D7(MSB)	D6	D5	D4	D3	D2	D1	D0
1	0	CSRP2	CSRP1	CSRP0	CC2	CC1	CC0

Function: These commands instruct the ADC to perform a calibration on the physical input channel selected by the setup register which is chosen by the command byte pointer bits (CSRP2 - CSRP0).

CSRP [2:0] (Channel Setup Register Pointer Bits)

000	Setup 1 (All devices)
001	Setup 2 (All devices)
010	Setup 3 (All devices)
011	Setup 4 (All devices)
100	Setup 5 (All devices)
101	Setup 6 (All devices)
110	Setup 7 (All devices)
111	Setup 8 (All devices)

CC [2:0] (Calibration Control Bits)

000	Reserved
001	Self-Offset Calibration
010	Self-Gain Calibration
011	Reserved
100	Reserved
101	System-Offset Calibration
110	System-Gain Calibration
111	Reserved

SYNC1

D7(MSB)	D6	D5	D4	D3	D2	D1	D0
1	1	1	1	1	1	1	1

Function: Part of the serial port re-initialization sequence.

SYNC0

D7(MSB)	D6	D5	D4	D3	D2	D1	D0
1	1	1	1	1	1	1	0

Function: End of the serial port re-initialization sequence.

NULL

D7(MSB)	D6	D5	D4	D3	D2	D1	D0
0	0	0	0	0	0	0	0

Function: This command is used to clear a port flag and keep the converter in the continuous conversion mode.

2.2.4. Serial Port Interface

The CS5531/32/33/34's serial interface consists of four control lines: \overline{CS} , SDI, SDO, SCLK. Figure 7 details the command and data word timing.

\overline{CS} , Chip Select, is the control line which enables access to the serial port. If the \overline{CS} pin is tied low, the port can function as a three wire interface.

SDI, Serial Data In, is the data signal used to transfer data to the converters.

SDO, Serial Data Out, is the data signal used to transfer output data from the converters. The SDO output will be held at high impedance any time \overline{CS} is at logic 1.

SCLK, Serial Clock, is the serial bit-clock which controls the shifting of data to or from the ADC's serial port. The \overline{CS} pin must be held low (logic 0) before SCLK transitions can be recognized by the port logic. To accommodate optoisolators SCLK is designed with a Schmitt-trigger input to allow an optoisolator with slower rise and fall times to directly drive the pin. Additionally, SDO is capable of sinking or sourcing up to 5 mA to directly drive an optoisolator LED. SDO will have less than a 400 mV loss in the drive voltage when sinking or sourcing 5 mA.

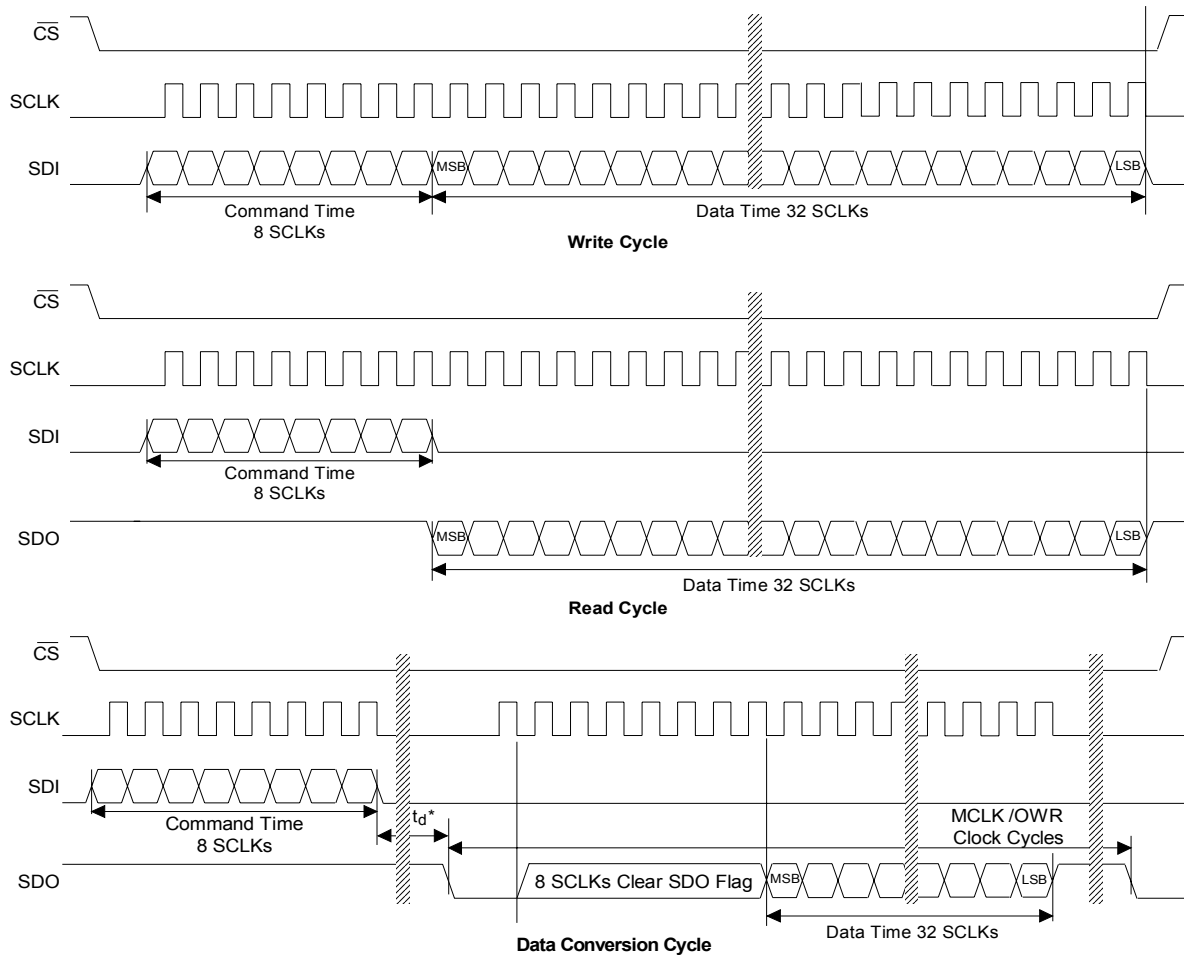

* t_d is the time it takes the ADC to perform a conversion. See the Single Conversion and Continuous Conversion sections of the data sheet for more details about conversion timing.

Figure 7. Command and Data Word Timing

2.2.5. Reading/Writing On-Chip Registers

The CS5531/32/33/34's offset, gain, configuration, and channel-setup registers are readable and writable while the conversion data register is read only.

As shown in Figure 7, to write to a particular register the user must transmit the appropriate write command and then follow that command by 32 bits of data. For example, to write 0x80000000 (hexadecimal) to physical channel one's gain register, the user would first transmit the command byte 0x02 (hexadecimal) followed by the data 0x80000000 (hexadecimal). Similarly, to read a particular register the user must transmit the appropriate read command and then acquire the 32 bits of data. Once a register is written to or read from, the serial port returns to the command mode.

In addition to accessing the internal registers one at a time, the gain and offset registers as well as the channel setup registers can be accessed as arrays (i.e. the entire register set can be accessed with one command). In the CS5531/32, there are two gain and offset registers, and in the CS5533/34, there are four gain and offset registers. There are four channel setup registers in all parts. As an example, to write 0x80000000 (hexadecimal) to all four gain registers in the CS5533, the user would transmit the command 0x42 (hexadecimal) followed by four iterations of 0x80000000 (hexadecimal), (i.e. 0x42 followed by 0x80000000, 0x80000000, 0x80000000, 0x80000000). The registers are written to or read from in sequential order (i.e., 1, followed by 2, 3, and 4). Once the registers are written to or read from, the serial port returns to the command mode.

2.3. Configuration Register

To ease the architectural design and simplify the serial interface, the configuration register is thirty-two bits long, however, only eleven of the thirty two bits are used. The following sections detail the bits in the configuration register.

2.3.1. Power Consumption

The CS5531/32/33/34 accommodate three power consumption modes: normal, standby, and sleep. The default mode, "normal mode", is entered after power is applied. In this mode, the CS5531/32/33/34-AS versions typically consume 35 mW. The CS5532/34-BS versions typically consume 70 mW. The other two modes are referred to as the power save modes. They power down most of the analog portion of the chip and stop filter convolutions. The power save modes are entered whenever the power down (PDW) bit of the configuration register is set to logic 1. The particular power save mode entered depends on state of the PSS (Power Save Select) bit. If PSS is logic 0, the converter enters the standby mode reducing the power consumption to 4 mW. The standby mode leaves the oscillator and the on-chip bias generator for the analog portion of the chip active. This allows the converter to quickly return to the normal mode once PDW is set back to a logic 1. If PSS and PDW are both set to logic 1, the sleep mode is entered reducing the consumed power to around 500 μ W. Since this sleep mode disables the oscillator, approximately a 20 ms oscillator start-up delay period is required before returning to the normal mode. If an external clock is used, there will be no delay. Further note that when the chips are used in the Gain = 1 mode, the PGIA is powered down. With the PGIA powered down, the power consumed in the normal power mode is reduced by approximately 1/2. Power consumption in the sleep and standby modes is not affected by the amplifier setting.

2.3.2. System Reset Sequence

The reset system (RS) bit permits the user to perform a system reset. A system reset can be initiated at any time by writing a logic 1 to the RS bit in the configuration register. After the RS bit has been set, the internal logic of the chip will be initialized to a reset state. The reset valid (RV) bit is set indicating that the internal logic was properly reset. The RV bit is cleared after the configuration regis-

ter is read. The on-chip registers are initialized to the following default states:

Configuration Register:	00000000(H)
Offset Registers:	00000000(H)
Gain Registers:	01000000(H)
Channel Setup Registers:	00000000(H)

After reset, the RS bit should be written back to logic 0 to complete the reset cycle. The ADC will return to the command mode where it waits for a valid command. Also, the RS bit is the only bit in the configuration register that can be set when initiating a reset (i.e. a second write command is needed to set other bits in the Configuration Register after the RS bit has been cleared).

2.3.3. Input Short

The input short bit allows the user to internally ground all the inputs of the multiplexer. This is a useful function because it allows the user to easily test the grounded input performance of the ADC and eliminate the noise effects due to the external system components.

2.3.4. Guard Signal

The guard signal bit is a bit that modifies the function of A0. When set, this bit outputs the common mode voltage of the instrumentation amplifier on A0. This feature is useful when the user wants to connect an external shield to the common mode potential of the instrumentation amplifier to protect against leakage. Figure 8 illustrates a typical connection diagram for the guard signal.

2.3.5. Voltage Reference Select

The voltage reference select (VRS) bit selects the size of the sampling capacitor used to sample the voltage reference. The bit should be set based upon the magnitude of the reference voltage to achieve optimal performance. Figures 9 and 10 model the effects on the reference's input impedance and input current for each VRS setting. As the models show, the reference includes a coarse/fine charge

buffer which reduces the dynamic current demand of the external reference.

The reference's input buffer is designed to accommodate rail-to-rail (common-mode plus signal) input voltages. The differential voltage between the VREF+ and VREF- can be any voltage from 1.0 V up to the analog supply (depending on how VRS is configured), however, the VREF+ cannot go above VA+ and the VREF- pin can not go below VA-. Note that the power supplies to the chip should be established before the reference voltage.

2.3.6. Output Latch Pins

The A1-A0 pins of the ADCs mimic the D21-D20/D5-D4 bits of the channel-setup registers if the output latch select (OLS) bit is logic 0 (default). If the OLS bit is logic 1, A1-A0 mimic the output latch bit settings in the configuration register. These two options give the user a choice of allowing the latch outputs to change anytime a different CSR is selected for a conversion, or to allow the latch bits to remain latched to a fixed state (determined by the configuration register bit) for all CSR selections. In either case, A1-A0 can be used to control external multiplexers and other logic functions outside the converter. The A1-A0 outputs can sink or source at least 1 mA, but it is recommended to limit drive currents to less than 20 μ A to reduce self-heating of the chip. These outputs are powered

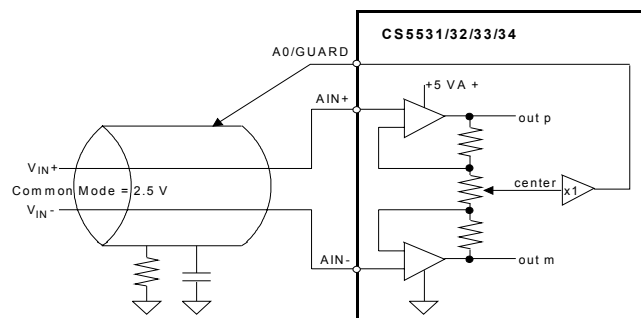

Figure 8. Guard Signal Shielding Scheme

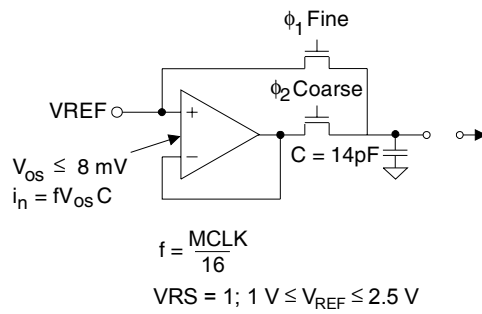

Figure 9. Input Reference Model when VRS = 1

from VA+ and VA-. Their output voltage will be limited to the VA+ voltage for a logic 1 and VA- for a logic 0.

2.3.7. Offset and Gain Select

The Offset and Gain Select bit (OGS) is used to select the source of the calibration registers to use when performing conversions and calibrations. When the OGS bit is set to '0', the offset and gain registers corresponding to the desired physical channel (CS1-CS0 in the selected Setup) will be accessed. When the OGS bit is set to '1', the offset and gain registers pointed to by the OG1-OG0 bits in the selected Setup will be accessed. This feature allows multiple calibration values (e.g. for different gain settings) to be used on a single physical channel without having to re-calibrate or manipulate the calibration registers.

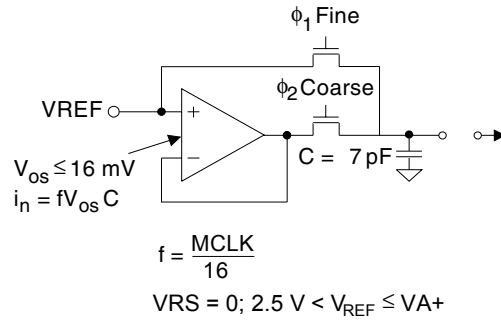

Figure 10. Input Reference Model when VRS = 0

2.3.8. Filter Rate Select

The Filter Rate Select bit (FRS) modifies the output word rates of the converter to allow either 50 Hz or 60 Hz rejection when operating from a 4.9152 MHz crystal. If FRS is cleared to logic 0, the word rates and corresponding filter characteristics can be selected (using the Channel Setup Registers) from 7.5, 15, 30, 60, 120, 240, 480, 960, 1920, or 3840 Sps when using a 4.9152 MHz clock. If FRS is set to logic 1, the word rates and corresponding filter characteristics scale by a factor of 5/6, making the selectable word rates 6.25, 12.5, 25, 50, 100, 200, 400, 800, 1600, and 3200 Sps when using a 4.9152 MHz clock. When using other clock frequencies, these selectable word rates will scale linearly with the clock frequency that is used.

2.3.9. Configuration Register Descriptions

D31(MSB)	D30	D29	D28	D27	D26	D25	D24	D23	D22	D21	D20	D19	D18	D17	D16
PSS	PDW	RS	RV	IS	GB	VRS	A1	A0	OLS	NU	OGS	FRS	NU	NU	NU
D15	D14	D13	D12	D11	D10	D9	D8	D7	D6	D5	D4	D3	D2	D1	D0
NU	NU	NU	NU	NU	NU	NU	NU	NU	NU	NU	NU	NU	NU	NU	NU

PSS (Power Save Select)[31]

- 0 Standby Mode (Oscillator active, allows quick power-up).
- 1 Sleep Mode (Oscillator inactive).

PDW (Power Down Mode)[30]

- 0 Normal Mode
- 1 Activate the power save select mode.

RS (Reset System)[29]

- 0 Normal Operation.
- 1 Activate a Reset cycle. See System Reset Sequence in the datasheet text.

RV (Reset Valid)[28]

- 0 Normal Operation
- 1 System was reset. This bit is read only. Bit is cleared to logic zero after the configuration register is read.

IS (Input Short)[27]

- 0 Normal Input
- 1 All signal input pairs for each channel are disconnected from the pins and shorted internally.

GB (Guard Signal Bit)[26]

- 0 Normal Operation of A0 as an output latch.
- 1 A0's output is modified to output the common mode output voltage of the instrumentation amplifier (typically 2.5 V). The output latch select bit is ignored when the guard buffer is activated.

VRS (Voltage Reference Select)[25]

- 0 $2.5\text{ V} < V_{\text{REF}} \leq [(VA+) - (VA-)]$
- 1 $1\text{ V} \leq V_{\text{REF}} \leq 2.5\text{ V}$

A1-A0 (Output Latch bits)[24:23]

The latch bits (A0 and A1) will be set to the logic state of these bits upon command word execution if the output latch select bit (OLS) is set. Note that these logic outputs are powered from VA+ and VA-.

- 00 A0 = 0, A1 = 0
- 01 A0 = 0, A1 = 1
- 10 A0 = 1, A1 = 0
- 11 A0 = 1, A1 = 1

Output Latch Select, OLS[22]

- 0 When low, uses the Channel-Setup Register as the source of A1 and A0.
- 1 When set, uses the Configuration Register as the source of A1 and A0.

NU (Not Used)[21]

- 0 Must always be logic 0. Reserved for future upgrades.

Offset and Gain Select OGS[20]

- 0 Calibration registers used are based on the CS1-CS0 bits of the referenced Setup.
- 1 Calibration registers used are based on the OG1-OG0 bits of the referenced Setup.

Filter Rate Select, FRS[19]

- 0 Use the default output word rates.
- 1 Scale all output word rates and their corresponding filter characteristics by a factor of 5/6.

NU (Not Used)[18:0]

- 0 Must always be logic 0. Reserved for future upgrades.

2.4. Setting up the CSRs for a Measurement

The CS5531/32/33/34 have four Channel-Setup Registers (CSRs). Each CSR contains two 16-bit Setups which are programmed by the user to contain data conversion information such as: 1) which physical channel will be converted, 2) at what gain will the channel be converted, 3) at what word rate will the channel be converted, 4) will the output conversion be unipolar or bipolar, 5) what will be the state of the output latch during the conversion, 6) will the converter delay the start of a conversion to allow time for the output latch to settle before the conversion is begun, and 7) will the open circuit detect current source be activated for that Setup. In addition, when the OGS bit in the Configuration Register is set, the Setup selects which set of offset and gain registers to use when performing conversions or calibrations. Note that a particular physical input channel can be represented in more than one Setup with

different output rates, gain ranges, etc. (i.e. each Setup is independently defined). Refer to section 2.4.1 for more details about the Channel Setup Registers.

Each 32-bit CSR is individually accessible and contains two 16-bit Setups. As an example, to configure Setup 1 in the CS5531/32/33/34 with the write individual channel-setup register command (0x05 hexadecimal), bits 31 to 16 of CSR 1 contains the information for Setup 1 and bits 15 to 0 contain the information for Setup 2. Note that while reading/writing CSRs, two Setups are accessed in pairs as a single 32-bit CSR register. Even if one of the Setups isn't used, it must be written to or read. Examples detailing the power of the CSRs are provided in section 2.6.3.

2.4.1. Channel-Setup Register Descriptions

CSR

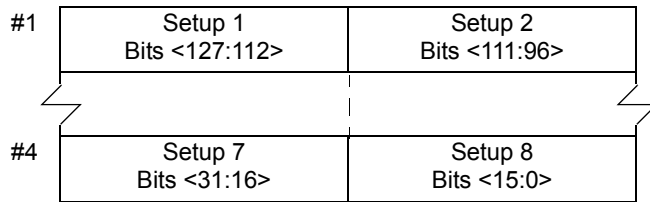

D31(MSB)	D30	D29	D28	D27	D26	D25	D24	D23	D22	D21	D20	D19	D18	D17	D16
CS1	CS0	G2	G1	G0	WR3	WR2	WR1	WR0	U/B	OL1	OL0	DT	OCD	OG1	OG0
D15	D14	D13	D12	D11	D10	D9	D8	D7	D6	D5	D4	D3	D2	D1	D0
CS1	CS0	G2	G1	G0	WR3	WR2	WR1	WR0	U/B	OL1	OL0	DT	OCD	OG1	OG0

CS1-CS0 (Channel Select Bits) [31:30] [15:14]

- 00 Select physical channel 1 (All devices)
- 01 Select physical channel 2 (All devices)
- 10 Select physical channel 3 (CS5533/34 only)
- 11 Select physical channel 4 (CS5533/34 only)

G2-G0 (Gain Bits) [29:27] [13:11]

For VRS = 0, A = 2; For VRS = 1, A = 1; Bipolar input span is twice the unipolar input span.

- 000 Gain = 1, (Input Span = [(VREF+)-(VREF-)]/1*A for unipolar).
- 001 Gain = 2, (Input Span = [(VREF+)-(VREF-)]/2*A for unipolar).
- 010 Gain = 4, (Input Span = [(VREF+)-(VREF-)]/4*A for unipolar).
- 011 Gain = 8, (Input Span = [(VREF+)-(VREF-)]/8*A for unipolar).
- 100 Gain = 16, (Input Span = [(VREF+)-(VREF-)]/16*A for unipolar).
- 101 Gain = 32, (Input Span = [(VREF+)-(VREF-)]/32*A for unipolar).
- 110 Gain = 64, (Input Span = [(VREF+)-(VREF-)]/64*A for unipolar).

WR3-WR0 (Word Rate) [26:23] [10:7]

The listed Word Rates are for continuous conversion mode using a 4.9152 MHz clock. All word rates will scale linearly with the clock frequency used. The very first conversion using continuous conversion mode will last longer, as will conversions done with the single conversion mode. See the section on Performing Conversions and Tables 1 and 2 for more details.

Bit	WR (FRS = 0)	WR (FRS = 1)
0000	120 Sps	100 Sps
0001	60 Sps	50 Sps
0010	30 Sps	25 Sps
0011	15 Sps	12.5 Sps
0100	7.5 Sps	6.25 Sps
1000	3840 Sps	3200 Sps
1001	1920 Sps	1600 Sps
1010	960 Sps	800 Sps
1011	480 Sps	400 Sps
1100	240 Sps	200 Sps

All other combinations are not used.

U/B (Unipolar / Bipolar) [22] [6]

- 0 Select Bipolar mode.
- 1 Select Unipolar mode.

OL1-OL0 (Output Latch Bits) [21:20] [5:4]

The latch bits will be set to the logic state of these bits upon command word execution when the output latch select bit (OLS) in the configuration register is logic 0. Note that the logic outputs on the chip are powered from VA+ and VA-.

- 00 A0 = 0, A1 = 0
- 01 A0 = 0, A1 = 1
- 10 A0 = 1, A1 = 0
- 11 A0 = 1, A1 = 1

DT (Delay Time Bit) [19] [3]

When set, the converter will wait for a delay time before starting a conversion. This allows settling time for A0 and A1 outputs before a conversion begins. The delay time will be 1280 MCLK cycles when FRS = 0, and 1536 MCLK cycles when FRS = 1.

- 0 Begin Conversions Immediately.
- 1 Wait 1280 MCLK cycles (FRS = 0) or 1536 MCLK cycles (FRS = 1) before starting conversion.

OCD (Open Circuit Detect Bit) [18] [2]

When set, this bit activates a 300 nA current source on the input channel (AIN+) selected by the channel select bits. Note that the 300nA current source is rated at 25°C. At -55°C, the current source doubles to approximately 600nA. This feature is particularly useful in thermocouple applications when the user wants to drive a suspected open thermocouple lead to a supply rail.

- 0 Normal mode.
- 1 Activate current source.

OG1-OG0 (Offset / Gain Register Pointer Bits) [17:16] [1:0]

These bits are only used when OGS in the Configuration Register is set to '1'. They allow the user to select the offset and gain register to use while performing a conversion or calibration. When the OGS bit in the Configuration Register is set to '0', the offset and gain register for the referenced physical channel (CS1-CS0 bits of the Setup) will be used.

- 00 Use offset and gain register from physical channel 1
- 01 Use offset and gain register from physical channel 2
- 10 Use offset and gain register from physical channel 3
- 11 Use offset and gain register from physical channel 4

2.5. Calibration

Calibration is used to set the zero and gain slope of the ADC's transfer function. The CS5531/32/33/34 offer both self calibration and system calibration.

Note: After the ADCs are reset, they are functional and can perform measurements without being calibrated (remember that the VRS bit in the configuration register must be properly configured). In this case, the converter will utilize the initialized values of the on-chip registers (Gain = 1.0, Offset = 0.0) to calculate output words. Any initial offset and gain errors in the internal circuitry of the chip will remain.

2.5.1. Calibration Registers

The CS5531/32/33/34 converters have an individual offset and gain register for each channel input. The gain and offset registers, which are used during both self and system calibration, are used to set the zero and gain slope of the converter's transfer function. As shown in *Offset Register* section, one LSB in the offset register is $1.835007966 \times 2^{-24}$ propor-

tion of the input span (bipolar span is 2 times the unipolar span, gain register = 1.000...000 decimal). The MSB in the offset register determines if the offset to be trimmed is positive or negative (0 positive, 1 negative). Note that the magnitude of the offset that is trimmed from the input is mapped through the gain register. The converter can typically trim ± 100 percent of the input span. As shown in the *Gain Register* section, the gain register spans from 0 to $(64 - 2^{-24})$. The decimal equivalent meaning of the gain register is

$$D = b_{D29}2^5 + b_{D28}2^4 + b_{D27}2^3 + \dots + b_{D0}2^{-24} = \sum_{i=0}^{29} b_{Di}2^{(-24+i)}$$

where the binary numbers have a value of either zero or one (b_{D29} is the binary value of bit D29). While gain register settings of up to $64 - 2^{-24}$ are available, the gain register should never be set to values above 40.

2.5.2. Gain Register

MSB	D30	D29	D28	D27	D26	D25	D24	D23	D22	D21	D20	D19	D18	D17	D16
NU	NU	2^5	2^4	2^3	2^2	2^1	2^0	2^{-1}	2^{-2}	2^{-3}	2^{-4}	2^{-5}	2^{-6}	2^{-7}	2^{-8}
0	0	0	0	0	0	0	1	0	0	0	0	0	0	0	0
D15	D14	D13	D12	D11	D10	D9	D8	D7	D6	D5	D4	D3	D2	D1	LSB
2^{-9}	2^{-10}	2^{-11}	2^{-12}	2^{-13}	2^{-14}	2^{-15}	2^{-16}	2^{-17}	2^{-18}	2^{-19}	2^{-20}	2^{-21}	2^{-22}	2^{-23}	2^{-24}
0	0	0	0	0	0	0	0	0	0	0	0	0	0	0	0

The gain register span is from 0 to $(64 - 2^{-24})$. After Reset D24 is 1, all other bits are '0'.

2.5.3. Offset Register

MSB	D30	D29	D28	D27	D26	D25	D24	D23	D22	D21	D20	D19	D18	D17	D16
Sign	2^{-2}	2^{-3}	2^{-4}	2^{-5}	2^{-6}	2^{-7}	2^{-8}	2^{-9}	2^{-10}	2^{-11}	2^{-12}	2^{-13}	2^{-14}	2^{-15}	2^{-16}
0	0	0	0	0	0	0	0	0	0	0	0	0	0	0	0
D15	D14	D13	D12	D11	D10	D9	D8	D7	D6	D5	D4	D3	D2	D1	LSB
2^{-17}	2^{-18}	2^{-19}	2^{-20}	2^{-21}	2^{-22}	2^{-23}	2^{-24}	NU	NU	NU	NU	NU	NU	NU	NU
0	0	0	0	0	0	0	0	0	0	0	0	0	0	0	0

One LSB represents $1.835007966 \times 2^{-24}$ proportion of the input span (bipolar span is 2 times unipolar span). Offset and data word bits align by MSB. After reset, all bits are '0'. The offset register is stored as a 32-bit, two's complement number, where the last 8 bits are all 0.

2.5.4. Performing Calibrations

To perform a calibration, the user must send a command byte with its MSB=1, its pointer bits (CSRP2-CSRP0) set to address the desired Setup to calibrate, and the appropriate calibration bits (CC2-CC0) set to choose the type of calibration to be performed. Note that calibration assumes that the CSRs have been previously initialized because the information concerning the physical channel, its filter rate, gain range, and polarity, comes from the channel-setup register addressed by the pointer bits in the command byte. Once the CSRs are initialized, a calibration can be performed with one command byte.

The length of time it takes to do a calibration is slightly less than the amount of time it takes to do a single conversion (see Table 1 for single conversion timing). Offset calibration takes 608 clock cycles less than a single conversion when FRS = 0, and 729 clock cycles less when FRS = 1. Gain calibration takes 128 clock cycles less than a single conversion when FRS = 0, and 153 clock cycles less when FRS = 1.

Once a calibration cycle is complete, SDO falls and the results are automatically stored in either the gain or offset register for the physical channel being calibrated when the OGS bit in the Configuration Register is set to '0'. If the OGS bit is set to '1', the results will be stored in the register specified by the OG1-OG0 bits of the selected Setup. See the OGS bit description for more details (Section 2.3.7). SDO will remain low until the next command word is begun. If additional calibrations are performed while referencing the same calibration registers, the last calibration results will replace the

effects from the previous calibration as only one offset and gain register is available per physical channel. Only one calibration is performed with each command byte. To calibrate all the channels, additional calibration commands are necessary.

2.5.5. Self Calibration

The CS5531/32/33/34 offer both self offset and self gain calibrations. For the self-calibration of offset, the converters internally tie the inputs of the 1X amplifier together and routes them to the AIN- pin as shown in Figure 11. For accurate self-calibration of offset to occur, the AIN pins must be at the proper common-mode-voltage as specified in the *Analog Characteristics* section. Self offset calibration uses the 1X gain amplifier, and is therefore not valid in the 2X-64X gain ranges. A self offset calibration of these gain ranges can be performed by setting the IS bit in the configuration register to a '1', and performing a system offset calibration. The IS bit must be returned to '0' afterwards for normal operation of the device.

For self-calibration of gain, the differential inputs of the modulator are connected to VREF+ and VREF- as shown in Figure 12. Self-calibration of gain will not work with $(VREF+ - VREF-) > 2.5V$. Self-calibration of gain is performed in the GAIN = 1x mode without regard to the setup register's gain setting. Gain errors in the PGIA gain steps 2x to 64x are not calibrated as this would require an accurate low voltage source other than the reference voltage. A system calibration of gain should be performed if accurate gains are to be achieved on the ranges other than 1X, or when $(VREF+ - VREF-) > 2.5V$.

2.5.6. System Calibration

For the system calibration functions, the user must supply the converters calibration signals which represent ground and full scale. When a system offset calibration is performed, a ground referenced signal must be applied to the converters. Figure 13 illustrates system offset calibration.

As shown in Figure 14, the user must input a signal representing the positive full scale point to perform a system gain calibration. In either case, the calibration signals must be within the specified calibration limits for each specific calibration step (refer to the *System Calibration Specifications*).

2.5.7. Calibration Tips

Calibration steps are performed at the output word rate selected by the WR2-WR0 bits of the channel setup registers. Due to limited register lengths in the faster word-rate filters (240 Sps and higher),

channels that are used in these rates should also be calibrated in one of these word rates, and channels used in the lower word rates (120 Sps and lower) should be calibrated at one of these lower rates. Since higher word rates result in conversion words with more peak-to-peak noise, calibration should be performed at the lowest possible output word rate for maximum accuracy. For the 7.5 Sps to 120 Sps word rate settings, calibrations can be performed at 7.5 Sps, and for 240 Sps and higher, calibration can be performed at 240 Sps. To minimize digital noise near the device, the user should wait for each calibration step to be completed before reading or writing to the serial port. Reading the calibration registers and averaging multiple calibrations together can produce a more accurate calibration result. Note that accessing the ADC's serial port before a calibration has finished may result in the loss of synchronization between the mi-

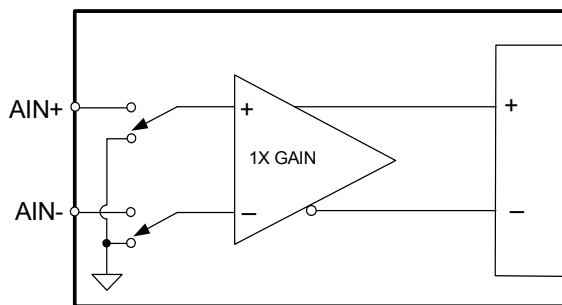

Figure 11. Self Calibration of Offset

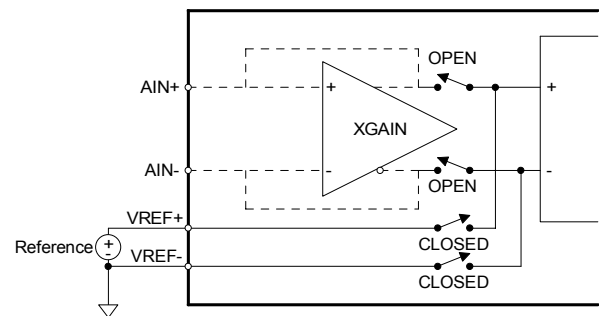

Figure 12. Self Calibration of Gain

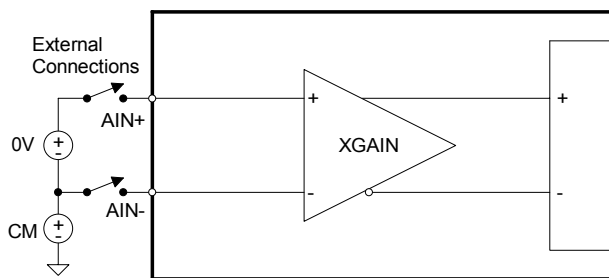

Figure 13. System Calibration of Offset

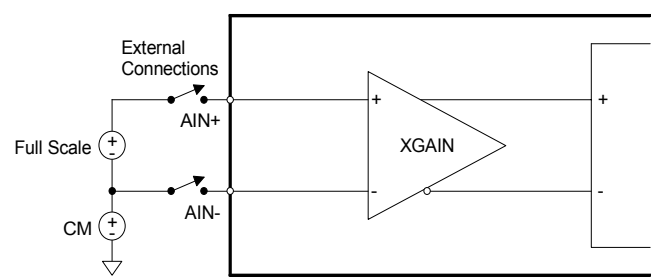

Figure 14. System Calibration of Gain

crocontroller and the ADC, and may prematurely halt the calibration cycle.

For maximum accuracy, calibrations should be performed for both offset and gain (selected by changing the G2-G0 bits of the channel-setup registers). Note that only one gain range can be calibrated per physical channel when the OGS bit in the Configuration Register is set to '0'. Multiple gain ranges can be calibrated for a single channel by manipulating the OGS bit and the OG1-OG0 bits of the selected Setup (see Section 2.3.7 for more details). If factory calibration of the user's system is performed using the system calibration capabilities of the CS5531/32/33/34, the offset and gain register contents can be read by the system microcontroller and recorded in non-volatile memory. These same calibration words can then be uploaded into the offset and gain registers of the converter when power is first applied to the system, or when the gain range is changed.

When the device is used without calibration, the uncalibrated gain accuracy is about ± 1 percent and the gain tracking from range (2X to 64X) to range is approximately ± 0.3 percent.

Note that the gain from the offset register to the output is 1.83007966 decimal, not 1. If a user wants to adjust the calibration coefficients externally, they will need to divide the information to be written to the offset register by the scale factor of 1.83007966. (This discussion assumes that the gain register is 1.000...000 decimal. The offset register is also multiplied by the gain register before being applied to the output conversion words).

2.5.8. Limitations in Calibration Range

System calibration can be limited by signal headroom in the analog signal path inside the chip as discussed under the *Analog Input* section of this data sheet. For gain calibration, the full scale input signal can be reduced to 3% of the nominal full-scale value. At this point, the gain register is approximately equal to 33.33 (decimal). While the

gain register can hold numbers all the way up to $64 - 2^{-24}$, gain register settings above a decimal value of 40 should not be used. With the converter's intrinsic gain error, this minimum full scale input signal may be higher or lower. In defining the minimum Full Scale Calibration Range (FSCR) under *Analog Characteristics*, margin is retained to accommodate the intrinsic gain error. Inversely, the input full scale signal can be increased to a point in which the modulator reaches its 1's density limit of 86 percent, which under nominal conditions occurs when the full scale input signal is 1.1 times the nominal full scale value. With the chip's intrinsic gain error, this maximum full scale input signal maybe higher or lower. In defining the maximum FSCR, margin is again incorporated to accommodate the intrinsic gain error.

2.6. Performing Conversions

The CS5531/32/33/34 offers two distinctly different conversion modes. The three sections that follow detail the differences and provide examples illustrating how to use the conversion modes with the channel-setup registers.

2.6.1. Single Conversion Mode

Based on the information provided in the channel-setup registers (CSRs), after the user transmits the conversion command, a single, fully-settled conversion is performed. The command byte includes a pointer address to the Setup register to be used during the conversion. Once transmitted, the serial port enters data mode where it waits until the conversion is complete. When the conversion data is available, SDO falls to logic 0. Forty SCLKs are then needed to read the conversion data word. The first 8 SCLKs are used to clear the SDO flag. During the first 8 SCLKs, SDI must be logic 0. The last 32 SCLKs are needed to read the conversion result. Note that the user is forced to read the conversion in single conversion mode as SDO will remain low (i.e. the serial port is in data mode) until SCLK transitions 40 times. After reading the data, the se-

rial port returns to the command mode, where it waits for a new command to be issued. The single conversion mode will take longer than conversions performed in the continuous conversion mode. The number of clock cycles a single conversion takes for each Output Word Rate (OWR) setting is listed in Table 1. The ± 8 (FRS = 0) or ± 10 (FRS = 1) clock ambiguity is due to internal synchronization between the SCLK input and the oscillator.

Note: In the single conversion mode, more than one conversion is actually performed, but only the final, fully settled result is output to the conversion data register.

(WR3-WR0)	Clock Cycles	
	FRS = 0	FRS = 1
0000	171448 \pm 8	205738 \pm 10
0001	335288 \pm 8	402346 \pm 10
0010	662968 \pm 8	795562 \pm 10
0011	1318328 \pm 8	1581994 \pm 10
0100	2629048 \pm 8	3154858 \pm 10
1000	7592 \pm 8	9110 \pm 10
1001	17848 \pm 8	21418 \pm 10
1010	28088 \pm 8	33706 \pm 10
1011	48568 \pm 8	58282 \pm 10
1100	89528 \pm 8	107434 \pm 10

Table 1. Conversion Timing for Single Mode

2.6.2. Continuous Conversion Mode

Based on the information provided in the channel-setup registers (CSRs), continuous conversions are performed using the Setup register contents pointed to by the conversion command. The command byte includes a pointer address to the Setup register to be used during the conversion. Once transmitted, the serial port enters data mode where it waits until a conversion is complete. After the conversion is done, SDO falls to logic 0. Forty SCLKs are then needed to read the conversion. The first 8 SCLKs are used to clear the SDO flag. The last 32 SCLKs are needed to read the conversion result. If '00000000' is provided to SDI during the first 8 SCLKs when the SDO flag is cleared, the converter remains in this conversion mode and continues to

convert the selected channel using the same CSR Setup. In continuous conversion mode, not every conversion word needs to be read. The user needs only to read the conversion words required for the application as SDO rises and falls to indicate the availability of new conversion data. Note that if a conversion is not read before the next conversion data becomes available, it will be lost and replaced by the new conversion data. To exit this conversion mode, the user must provide '11111111' to the SDI pin during the first 8 SCLKs after SDO falls. If the user decides to exit, 32 SCLKs are required to clock out the last conversion before the converter returns to command mode. The number of clock cycles a continuous conversion takes for each Output Word Setting is listed in Table 2. The first conversion from the part in continuous conversion mode will be longer than the following conversions due to start-up overhead. The ± 8 (FRS = 0) or ± 10 (FRS = 1) clock ambiguity is due to internal synchronization between the SCLK input and the oscillator.

Note: When changing channels, or after performing calibrations and/or single conversions, the user must ignore the first three (for OWRs less than 3200 Sps, MCLK = 4.9152 MHz) or first five (for OWR \geq 3200 Sps) conversions in continuous conversion mode, as residual filter coefficients must be flushed from the filter before accurate conversions are performed.

FRS	(WR3-WR0)	Clock Cycles (First Conversion)	Clock Cycles (All Other Conversions)
0	0000	89528 \pm 8	40960
0	0001	171448 \pm 8	81920
0	0010	335288 \pm 8	163840
0	0011	662968 \pm 8	327680
0	0100	1318328 \pm 8	655360
0	1000	2472 \pm 8	1280
0	1001	12728 \pm 8	2560
0	1010	17848 \pm 8	5120
0	1011	28088 \pm 8	10240
0	1100	48568 \pm 8	20480

FRS	(WR3-WR0)	Clock Cycles (First Conversion)	Clock Cycles (All Other Conversions)
1	0000	107434 ± 10	49152
1	0001	205738 ± 10	98304
1	0010	402346 ± 10	196608
1	0011	795562 ± 10	393216
1	0100	1581994 ± 10	786432
1	1000	2966 ± 10	1536
1	1001	15274 ± 10	3072
1	1010	21418 ± 10	6144
1	1011	33706 ± 10	12288
1	1100	58282 ± 10	24576

Table 2. Conversion Timing for Continuous Mode

2.6.3. Examples of Using CSRs to Perform Conversions and Calibrations

Any time a calibration or conversion command is issued (C, MC, and CC2-CC0 bits must be properly set), the CSR_{P2}-CSR_{P0} bits in the command byte are used as pointers to address one of the Setups in the channel-setup registers (CSRs). Table 3 details the address decoding of the pointer the bits.

(CSR _{P2} -CSR _{P0})	CSR Location	Setup
000	CSR #1	1
001	CSR #1	2
010	CSR #2	3
011	CSR #2	4
100	CSR #3	5
101	CSR #3	6
110	CSR#4	7
111	CSR #4	8

Table 3. Command Byte Pointer

The examples that follow detail situations that a user might encounter when acquiring a conversion or calibrating the converter. These examples assume that the CSRs are programmed with the following physical channel order: 4, 1, 1, 2, 4, 3, 4, 4.

A physical channel is defined as the actual input channel (AIN1 to AIN4) to which an external signal is connected.

Example 1: Single conversion using Setup 1. The command issued is ‘10000000’. This instructs the converter to perform a single conversion referencing Setup 1 (CSR_{P2} - CSR_{P0} = ‘000’) In this example, Setup 1 points to physical channel 4. After the command is received and decoded, the ADC performs a conversion on physical channel 4 and SDO falls to indicate that the conversion is complete. To read the conversion, 40 SCLKs are then required. Once the conversion data has been read, the serial port returns to the command mode.

Example 2: Continuous conversions using Setup 3. The command issued is ‘11010000’. This instructs the converter to perform continuous conversions referencing Setup 3 (CSR_{P2} - CSR_{P0} = ‘010’). In this example, Setup 3 points to physical channel 1. After the command is received and decoded, the ADC performs a conversion on physical channel 1 and SDO falls to indicate that the conversion is complete. The user now has three options. The user can acquire the conversion and remain in this mode, acquire the conversion and exit this mode, or ignore the conversion and wait for a new conversion at the next update interval, as detailed in the continuous conversion section.

Example 3: Calibration using Setup 4. This example assumes that the OGS bit in the Configuration Register is set to ‘0’. The command issued is ‘10011001’. This instructs the converter to perform a self offset calibration referencing Setup 4 (CSR_{P2} - CSR_{P0} = ‘011’). In this example, Setup 4 points to physical channel 2. After the command is received and decoded, the ADC performs a self offset calibration on physical channel 2 and SDO falls to indicate that the calibration is complete. To perform additional calibrations, more commands must be issued.

Note: The CSRs need not be written. If they are not initialized, all the Setups point to their default settings irrespective of the conversion or calibration mode (i.e conversions can be performed, but only physical channel 1 will be converted). Further note that filter

convolutions are reset (i.e. flushed) if consecutive conversions are performed on two different physical channels. If consecutive conversions are performed on the same physical channel, the filter is not reset. This allows the ADCs to more quickly settle full scale step inputs.

2.7. Using Multiple ADCs Synchronously

Some applications require synchronous data outputs from multiple ADCs converting different analog channels. Multiple CS5531/32/33/34 parts can be synchronized in a single system by using the following guidelines:

- 1) All of the ADCs in the system must be operated from the same oscillator source.
- 2) All of the ADCs in the system must share common SCLK and SDI lines.
- 3) A software reset must be performed at the same time for all of the ADCs after system power-up (by selecting all of the ADCs using their respective \overline{CS} pins, and writing the reset sequence to all parts, using SDI and SCLK).
- 4) A start conversion command must be sent to all of the ADCs in the system at the same time. The ± 8 clock cycles of ambiguity for the first conversion (or for a single conversion) will be the same for all ADCs, provided that they were all reset at the same time.
- 5) Conversions can be obtained by monitoring SDO on only one ADC, (bring \overline{CS} high for all but one part) and reading the data out of each part individually, before the next conversion data words are ready.

An example of a synchronous system using two CS5532 parts is shown in Figure 15.

2.8. Conversion Output Coding

The CS5531/32/33/34 output 16-bit (CS5531/33) and 24-bit (CS5532/34) data conversion words. To read a conversion word the user must read the conversion data register. The conversion data register is 32 bits long and outputs the conversions MSB

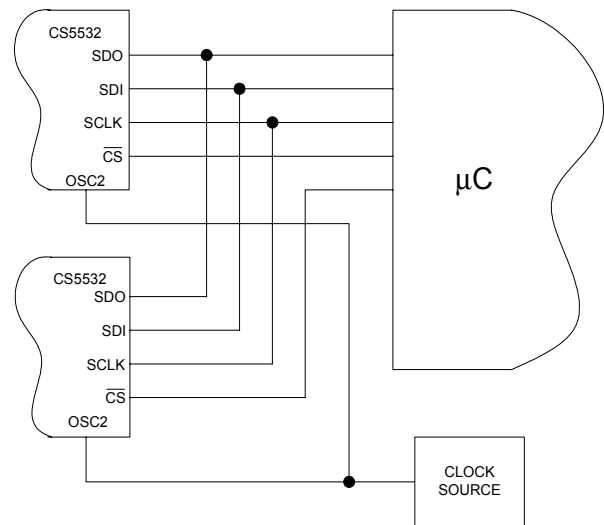

Figure 15. Synchronizing Multiple ADCs

first. The last byte of the conversion data register contains data monitoring flags. The channel indicator (CI) bits keep track of which physical channel was converted and the overrange flag (OF) monitors to determine if a valid conversion was performed. Refer to the *Conversion Data Output Descriptions* section for more details.

The CS5531/32/33/34 output data conversions in binary format when operating in unipolar mode and in two's complement when operating in bipolar mode. Tables 4 and 5 show the code mapping for both unipolar and bipolar mode. VFS in the tables refers to the positive full-scale voltage range of the converter in the specified gain range, and -VFS re-

Unipolar Input Voltage	Offset Binary	Bipolar Input Voltage	Two's Complement
>(VFS-1.5 LSB)	FFFF	>(VFS-1.5 LSB)	7FFF
VFS-1.5 LSB	FFFF ----- FFFE	VFS-1.5 LSB	7FFF ----- 7FFE
VFS/2-0.5 LSB	8000 ----- 7FFF	-0.5 LSB	0000 ----- FFFF
+0.5 LSB	0001 ----- 0000	-VFS+0.5 LSB	8001 ----- 8000
<(+0.5 LSB)	0000	<(-VFS+0.5 LSB)	8000

Table 4. Output Coding for 16-bit CS5531 and

Unipolar Input Voltage	Offset Binary	Bipolar Input Voltage	Two's Complement
>(VFS-1.5 LSB)	FFFFFF	>(VFS-1.5 LSB)	7FFFFF
VFS-1.5 LSB	FFFFFF ----- FFFFFFE	VFS-1.5 LSB	7FFFFF ----- 7FFFFE
VFS/2-0.5 LSB	800000 ----- 7FFFFFF	-0.5 LSB	000000 ----- FFFFFFF
+0.5 LSB	000001 ----- 000000	-VFS+0.5 LSB	800001 ----- 800000
<(+0.5 LSB)	000000	<(-VFS+0.5 LSB)	800000

Table 5. Output Coding for 24-bit CS5532 and

fers to the negative full-scale voltage range of the converter. The total differential input range (between AIN+ and AIN-) is from 0 to VFS in unipolar mode, and from -VFS to VFS in bipolar mode.

2.8.1. Conversion Data Output Descriptions

CS5531/33 (16-BIT CONVERSIONS)

D31(MSB)	D30	D29	D28	D27	D26	D25	D24	D23	D22	D21	D20	D19	D18	D17	D16
MSB	14	13	12	11	10	9	8	7	6	5	4	3	2	1	LSB
D15	D14	D13	D12	D11	D10	D9	D8	D7	D6	D5	D4	D3	D2	D1	D0
0	0	0	0	0	0	0	0	0	0	0	0	0	0	OF	CI0

CS5532/34 (24-BIT CONVERSIONS)

D31(MSB)	D30	D29	D28	D27	D26	D25	D24	D23	D22	D21	D20	D19	D18	D17	D16
MSB	22	21	20	19	18	17	16	15	14	13	12	11	10	9	8
D15	D14	D13	D12	D11	D10	D9	D8	D7	D6	D5	D4	D3	D2	D1	D0
7	6	5	4	3	2	1	LSB	0	0	0	0	0	0	OF	CI0

Conversion Data Bits [31:16 for CS5531/33; 31:8 for CS5532/34]

These bits depict the latest output conversion.

NU (Not Used) [15:3 for CS5531/33; 7:3 for CS5532/34]

These bits are masked logic zero.

OF (Over-range Flag Bit) [2]

- 0 Bit is clear when over-range condition has not occurred.
- 1 Bit is set when input signal is more positive than the positive full scale, more negative than zero (unipolar mode) or when the input is more negative than the negative full scale (bipolar mode).

CI (Channel Indicator Bits) [1:0]

These bits indicate which physical input channel was converted.

- 00 Physical Channel 1
- 01 Physical Channel 2
- 10 Physical Channel 3
- 11 Physical Channel 4

2.9. Digital Filter

The CS5531/32/33/34 have linear phase digital filters which are programmed to achieve a range of output word rates (OWRs) as stated in the *Channel-Setup Register Descriptions* section. The ADCs use a Sinc⁵ digital filter to output word rates at 3200 Sps and 3840 Sps (MCLK = 4.9152 MHz). Other output word rates are achieved by using the Sinc⁵ filter followed by a Sinc³ filter with a programmable decimation rate. Figure 16 shows the magnitude response of the 60 Sps filter, while Figures 17 and 18 show the magnitude and phase response of the filter at 120 Sps. The Sinc³ is active for all output

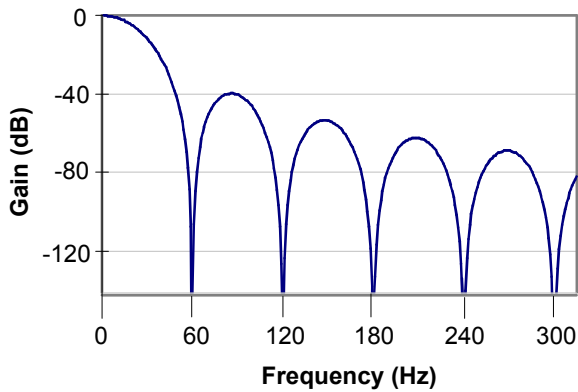

Figure 16. Digital Filter Response (Word Rate = 60 Sps)

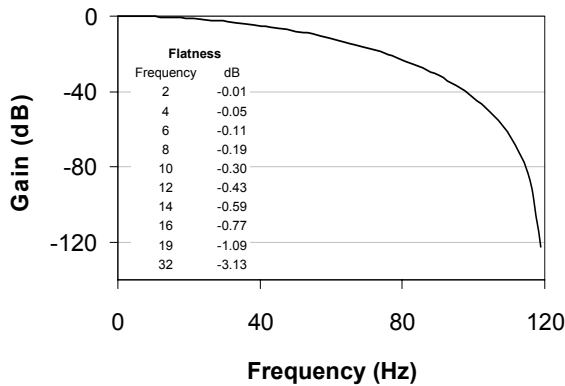

Figure 17. 120 Sps Filter Magnitude Plot to 120 Hz

word rates except for the 3200 Sps and 3840 Sps (MCLK = 4.9152 MHz) rate. The Z-transforms of the two filters are shown in Figure 19. For the Sinc³ filter, “D” is the programmable decimation ratio, which is equal to 3840/OWR when FRS = 0 and 3200/OWR when FRS = 1.

The converter’s digital filters scale with MCLK. For example, with an output word rate of 120 Sps, the filter’s corner frequency is at 31 Hz. If MCLK is increased to 5.0 MHz, the OWR increases by 1.0175 percent and the filter’s corner frequency moves to 31.54 Hz. Note that the converter is not specified to run at MCLK clock frequencies greater than 5 MHz.

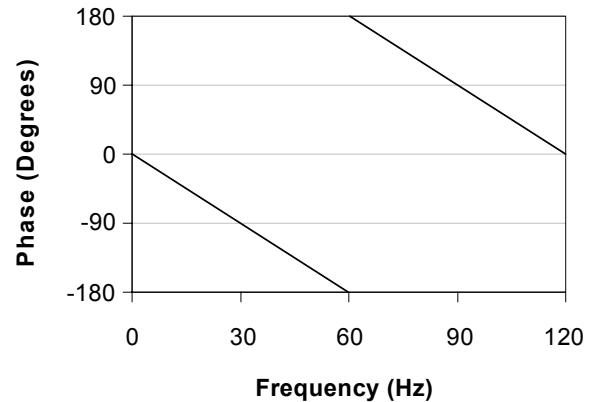

Figure 18. 120 Sps Filter Phase Plot to 120 Hz

$$\text{Sinc}^5 = \frac{(1-z^{-80})^5}{(1-z^{-16})^5} \times \frac{(1-z^{-16})^3}{(1-z^{-4})^3} \times \frac{(1-z^{-4})^2}{(1-z^{-2})^2} \times \frac{(1-z^{-2})^3}{(1-z^{-1})^3}$$

$$\text{Sinc}^3 = \frac{(1-z^{-D})^3}{(1-z^{-1})^3}$$

Note: See the text regarding the Sinc³ filter’s decimation ratio “D”.

Figure 19. Z-Transforms of Digital Filters

2.10. Clock Generator

The CS5531/32/33/34 include an on-chip inverting amplifier which can be connected with an external crystal to provide the master clock for the chip. Figure 20 illustrates the on-chip oscillator. It includes loading capacitors and a feedback resistor to form a Pierce oscillator configuration. The chips are designed to operate using a 4.9152 MHz crystal; however, other crystals with frequencies between 1 MHz to 5 MHz can be used. One lead of the crystal should be connected to OSC1 and the other to OSC2. Lead lengths should be minimized to reduce stray capacitance. Note that while using the on-chip oscillator, neither OSC1 or OSC2 is capable of directly driving any off chip logic. When the on-chip oscillator is used, the voltage on OSC2 is typically 1/2 V peak-to-peak. This signal is not compatible with external logic unless additional external circuitry is added. The OSC2 output should be used if the on-chip oscillator output is used to drive other circuitry.

The designer can use an external CMOS compatible oscillator to drive OSC2 with a 1 MHz to 5 MHz clock for the ADC. The external clock into OSC2 must overdrive the 60 microampere output of the on-chip amplifier. This will not harm the on-chip circuitry. In this scheme, OSC1 should be left unconnected.

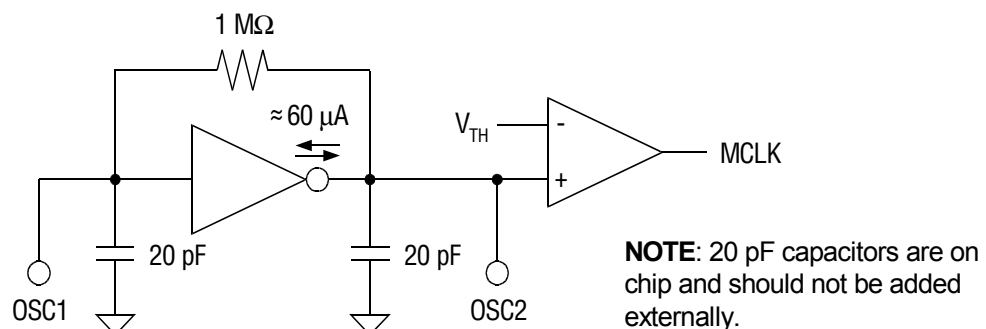

Figure 20. On-chip Oscillator Model

2.11. Power Supply Arrangements

The CS5531/32/33/34 are designed to operate from single or dual analog supplies and a single digital supply. The following power supply connections are possible:

$V_{A+} = +5\text{ V}$; $V_{A-} = 0\text{ V}$; $V_{D+} = +3\text{ V to } +5\text{ V}$

$V_{A+} = +2.5\text{ V}$; $V_{A-} = -2.5\text{ V}$; $V_{D+} = +3\text{ V to } +5\text{ V}$

$V_{A+} = +3\text{ V}$; $V_{A-} = -3\text{ V}$; $V_{D+} = +3\text{ V}$

A V_{A+} supply of +2.5 V, +3.0 V, or +5.0 V should be maintained at $\pm 5\%$ tolerance. A V_{A-} supply of -2.5 V or -3.0 V should be maintained at $\pm 5\%$ tolerance. V_{D+} can extend from +2.7 V to +5.5 V with the additional restriction that $[(V_{D+}) - (V_{A-}) < 7.5\text{ V}]$.

Figure 21 illustrates the CS5532 connected with a single +5.0 V supply to measure differential inputs relative to a common mode of 2.5 V. Figure 22 illustrates the CS5532 connected with $\pm 2.5\text{ V}$ bipolar analog supplies and a +3 V to +5 V digital supply to measure ground referenced bipolar signals. Figures 23 and 24 illustrate the CS5532 connected with $\pm 3\text{ V}$ analog supplies and a +3 V digital supply to measure ground referenced bipolar signals.

Figure 25 illustrates alternate bridge configurations which can be measured with the converter. Voltage V_1 can be measured with the PGIA gain set to 1x as the input amplifier on this gain setting can go rail-to-rail. Voltage V_2 should be measured with the PGIA gain set at 2x or higher as the instrumentation amplifier used on these gain ranges achieves lower noise.

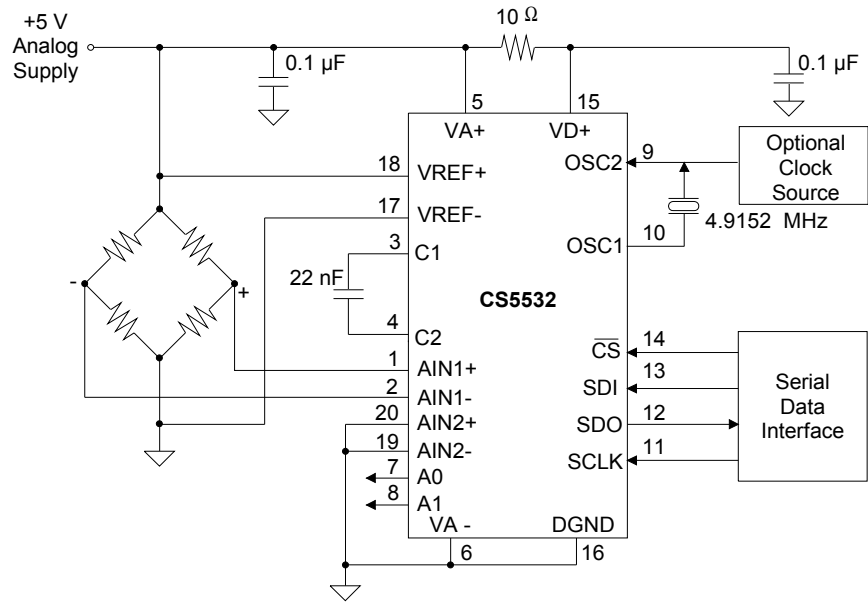

Figure 21. CS5532 Configured with a Single +5 V Supply

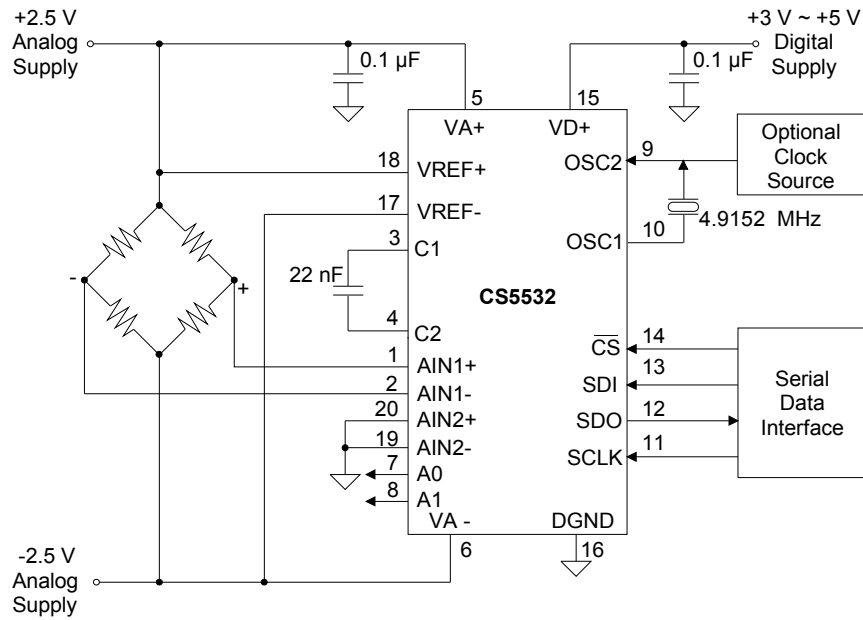

Figure 22. CS5532 Configured with ± 2.5 V Analog Supplies

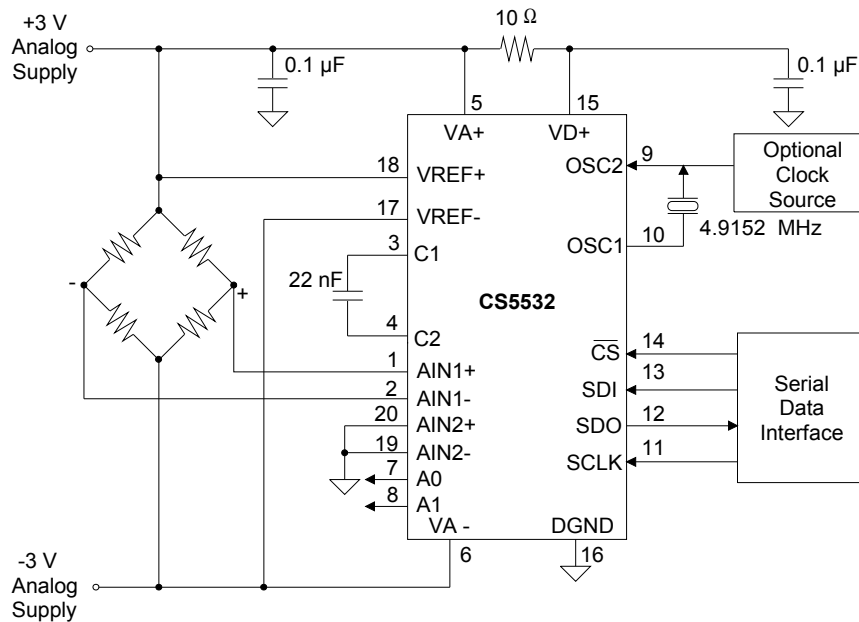

Figure 23. CS5532 Configured with ± 3 V Analog Supplies

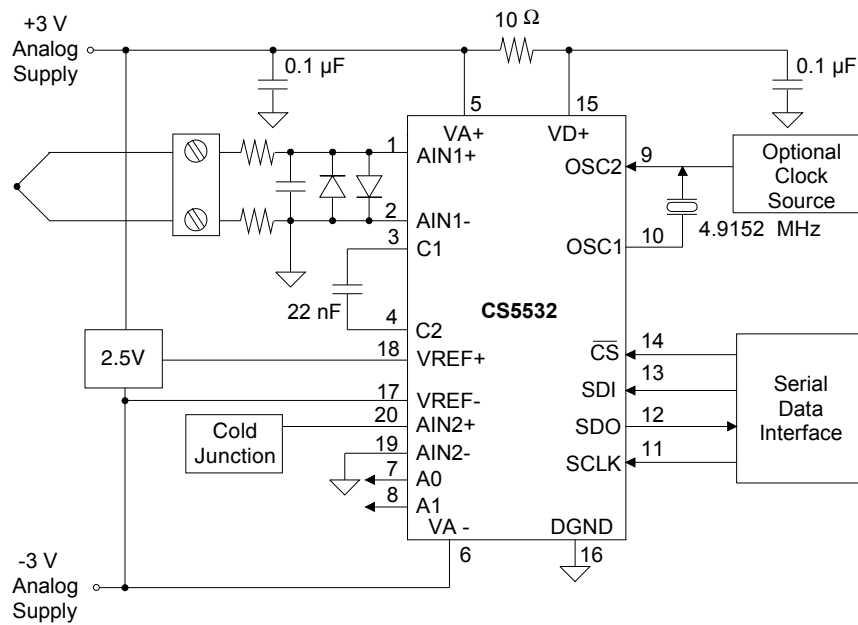

Figure 24. CS5532 Configured for Thermocouple Measurement

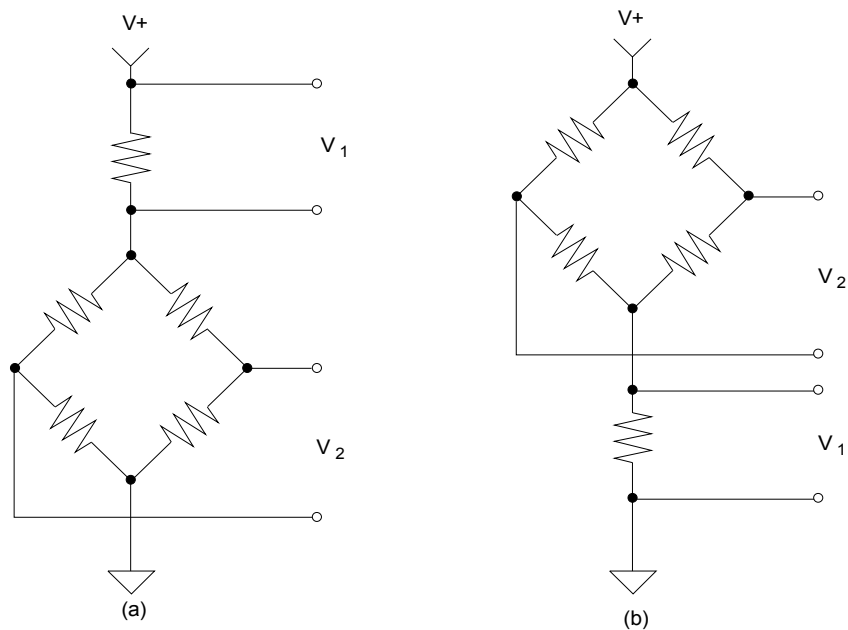

Figure 25. Bridge with Series Resistors

2.12. Getting Started

This A/D converter has several features. From a software programmer's prospective, what should be done first? To begin, a 4.9152 MHz or 4.096 MHz crystal takes approximately 20 ms to start. To accommodate for this, it is recommended that a software delay of approximately 20 ms start the processor's ADC initialization code. Next, since the CS5531/32/33/34 do not provide a power-on-reset function, the user must first initialize the ADC to a known state. This is accomplished by resetting the ADC's serial port with the Serial Port Initialization sequence. This sequence resets the serial port to the command mode and is accomplished by transmitting 15 SYNC1 command bytes (0xFF hexadecimal), followed by one SYNC0 command (0xFE hexadecimal). Once the serial port of the ADC is in the command mode, the user must reset all the internal logic by performing a system reset sequence (see 2.3.2 System Reset Sequence). The next action is to initialize the voltage reference mode. The voltage reference select (VRS) bit in the configuration register must be set based upon the

magnitude of the reference voltage between the VREF+ and the VREF- pins.

After this, the channel-setup registers (CSRs) should be initialized, as these registers determine how calibrations and conversions will be performed. Once the CSRs are initialized, the user has three options in calibrating the ADC: 1) don't calibrate and use the default settings; 2) perform self or system calibrations; or 3) upload previously saved calibration results to the offset and gain registers. At this point, the ADC is ready to perform conversions.

2.13. PCB Layout

For optimal performance, the CS5531/32/33/34 should be placed entirely over an analog ground plane. All grounded pins on the ADC, including the DGND pin, should be connected to the analog ground plane that runs beneath the chip. In a split-plane system, place the analog-digital plane split immediately adjacent to the digital portion of the chip.

3. PIN DESCRIPTIONS

DIFFERENTIAL ANALOG INPUT	AIN1+	1	20	AIN2+	DIFFERENTIAL ANALOG INPUT
DIFFERENTIAL ANALOG INPUT	AIN1-	2	19	AIN2-	DIFFERENTIAL ANALOG INPUT
AMPLIFIER CAPACITOR CONNECT	C1	3	18	VREF+	VOLTAGE REFERENCE INPUT
AMPLIFIER CAPACITOR CONNECT	C2	4	17	VREF-	VOLTAGE REFERENCE INPUT
POSITIVE ANALOG POWER	VA+	5	16	DGND	DIGITAL GROUND
NEGATIVE ANALOG POWER	VA-	6	15	VD+	POSITIVE DIGITAL POWER
LOGIC OUTPUT (ANALOG)/GUARD	A0	7	14	CS	CHIP SELECT
LOGIC OUTPUT (ANALOG)	A1	8	13	SDI	SERIAL DATA INPUT
MASTER CLOCK	OSC2	9	12	SDO	SERIAL DATA OUT
MASTER CLOCK	OSC1	10	11	SCLK	SERIAL CLOCK INPUT

DIFFERENTIAL ANALOG INPUT	AIN1+	1	24	AIN2+	DIFFERENTIAL ANALOG INPUT
DIFFERENTIAL ANALOG INPUT	AIN1-	2	23	AIN2-	DIFFERENTIAL ANALOG INPUT
DIFFERENTIAL ANALOG INPUT	AIN4+	3	22	AIN3+	DIFFERENTIAL ANALOG INPUT
DIFFERENTIAL ANALOG INPUT	AIN4-	4	21	AIN3-	DIFFERENTIAL ANALOG INPUT
AMPLIFIER CAPACITOR CONNECT	C1	5	20	VREF+	VOLTAGE REFERENCE INPUT
AMPLIFIER CAPACITOR CONNECT	C2	6	19	VREF-	VOLTAGE REFERENCE INPUT
POSITIVE ANALOG POWER	VA+	7	18	DGND	DIGITAL GROUND
NEGATIVE ANALOG POWER	VA-	8	17	VD+	POSITIVE DIGITAL POWER
LOGIC OUTPUT (ANALOG)/GUARD	A0	9	16	CS	CHIP SELECT
LOGIC OUTPUT (ANALOG)	A1	10	15	SDI	SERIAL DATA INPUT
MASTER CLOCK	OSC2	11	14	SDO	SERIAL DATA OUT
MASTER CLOCK	OSC1	12	13	SCLK	SERIAL CLOCK INPUT

Clock Generator

OSC1; OSC2 - Master Clock.

An inverting amplifier inside the chip is connected between these pins and can be used with a crystal to provide the master clock for the device. Alternatively, an external (CMOS compatible) clock (powered relative to VD+) can be supplied into the OSC2 pin to provide the master clock for the device.

Control Pins and Serial Data I/O

CS - Chip Select.

When active low, the port will recognize SCLK. When high the SDO pin will output a high impedance state. CS should be changed when SCLK = 0.

SDI - Serial Data Input.

SDI is the input pin of the serial input port. Data will be input at a rate determined by SCLK.

SDO - Serial Data Output.

SDO is the serial data output. It will output a high impedance state if $\overline{CS} = 1$.

SCLK - Serial Clock Input.

A clock signal on this pin determines the input/output rate of the data for the SDI/SDO pins respectively. This input is a Schmitt trigger to allow for slow rise time signals. The SCLK pin will recognize clocks only when \overline{CS} is low.

A0 - Logic Output (Analog)/Guard, A1 - Logic Output (Analog).

The logic states of A1-A0 mimic the OL1-OL0 bits in the selected Setup, or the A1-A0 bits in the Configuration Register, depending on the state of the OLS bit in the Configuration Register. Logic Output 0 = VA-, and Logic Output 1 = VA+. Alternately, A0 can be used as a guard drive for the instrumentation amplifier with proper setting of the GB bit in the Configuration Register.

Measurement and Reference Inputs**AIN1+, AIN1-, AIN2+, AIN2-, AIN3+, AIN3-, AIN4+, AIN4- - Differential Analog Input.**

Differential input pins into the device.

VREF+, VREF- - Voltage Reference Input.

Fully differential inputs which establish the voltage reference for the on-chip modulator.

C1, C2 - Amplifier Capacitor Inputs.

Connections for the instrumentation amplifier's capacitor.

Power Supply Connections**VA+ - Positive Analog Power.**

Positive analog supply voltage.

VD+ - Positive Digital Power.

Positive digital supply voltage (nominally +3.0 V or +5 V).

VA- - Negative Analog Power.

Negative analog supply voltage.

DGND - Digital Ground.

Digital Ground.

4. SPECIFICATION DEFINITIONS

Linearity Error

The deviation of a code from a straight line which connects the two endpoints of the ADC transfer function. One endpoint is located 1/2 LSB below the first code transition and the other endpoint is located 1/2 LSB beyond the code transition to all ones. Units in percent of full-scale.

Differential Nonlinearity

The deviation of a code's width from the ideal width. Units in LSBs.

Full Scale Error

The deviation of the last code transition from the ideal $[(V_{REF+}) - (V_{REF-})] - 3/2 \text{ LSB}$. Units are in LSBs.

Unipolar Offset

The deviation of the first code transition from the ideal (1/2 LSB above the voltage on the AIN-pin.). When in unipolar mode (U/B bit = 1). Units are in LSBs.

Bipolar Offset

The deviation of the mid-scale transition (111...111 to 000...000) from the ideal (1/2 LSB below the voltage on the AIN- pin). When in bipolar mode (U/B bit = 0). Units are in LSBs.

5. ORDERING GUIDE

Model Number	Bits	Channels	Linearity Error (Max)	Temperature Range	Package
CS5531-AS	16	2	±0.003%	-40°C to +85°C	20-pin 0.2" Plastic SSOP
CS5531-ASZ	16	2	±0.003%	-40°C to +85°C	20-pin 0.2" Plastic SSOP, Lead Free
CS5533-AS	16	4	±0.003%	-40°C to +85°C	24-pin 0.2" Plastic SSOP
CS5533-ASZ	16	4	±0.003%	-40°C to +85°C	24-pin 0.2" Plastic SSOP, Lead Free
CS5532-AS	24	2	±0.003%	-40°C to +85°C	20-pin 0.2" Plastic SSOP
CS5532-ASZ	24	2	±0.003%	-40°C to +85°C	20-pin 0.2" Plastic SSOP, Lead Free
CS5532-BS	24	2	±0.0015%	-40°C to +85°C	20-pin 0.2" Plastic SSOP
CS5532-BSZ	24	2	±0.0015%	-40°C to +85°C	20-pin 0.2" Plastic SSOP, Lead Free
CS5534-AS	24	4	±0.003%	-40°C to +85°C	24-pin 0.2" Plastic SSOP
CS5534-ASZ	24	4	±0.003%	-40°C to +85°C	24-pin 0.2" Plastic SSOP, Lead Free
CS5534-BS	24	4	±0.0015%	-40°C to +85°C	24-pin 0.2" Plastic SSOP
CS5534-BSZ	24	4	±0.0015%	-40°C to +85°C	24-pin 0.2" Plastic SSOP, Lead Free

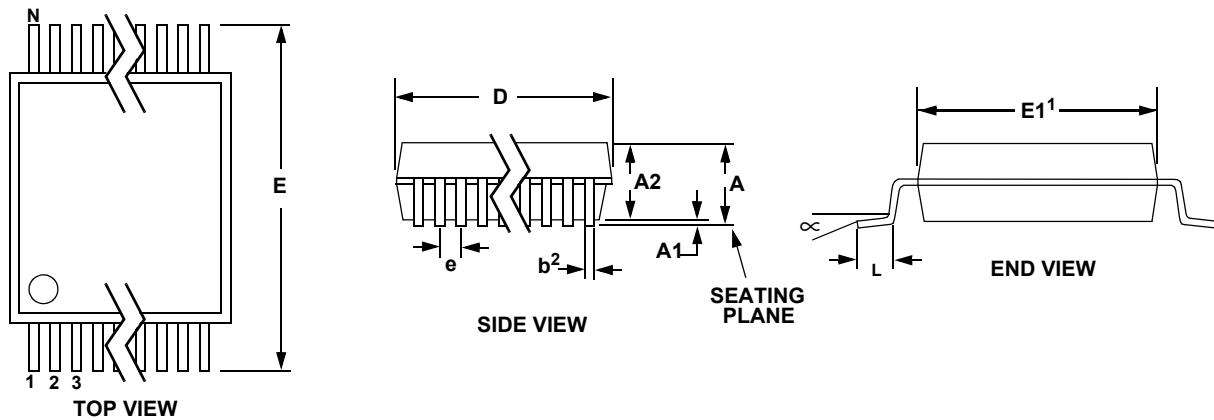
6. PACKAGE DRAWINGS
20 PIN SSOP PACKAGE DRAWING

DIM	INCHES		MILLIMETERS		NOTE
	MIN	MAX	MIN	MAX	
A	--	0.084	--	2.13	
A1	0.002	0.010	0.05	0.25	
A2	0.064	0.074	1.62	1.88	
b	0.009	0.015	0.22	0.38	2,3
D	0.272	0.295	6.90	7.50	1
E	0.291	0.323	7.40	8.20	
E1	0.197	0.220	5.00	5.60	1
e	0.024	0.027	0.61	0.69	
L	0.025	0.040	0.63	1.03	
∞	0°	8°	0°	8°	

- Notes:
1. "D" and "E1" are reference datums and do not include mold flash or protrusions, but do include mold mismatch and are measured at the parting line, mold flash or protrusions shall not exceed 0.20 mm per side.
 2. Dimension "b" does not include dambar protrusion/intrusion. Allowable dambar protrusion shall be 0.13 mm total in excess of "b" dimension at maximum material condition. Dambar intrusion shall not reduce dimension "b" by more than 0.07 mm at least material condition.
 3. These dimensions apply to the flat section of the lead between 0.10 and 0.25 mm from lead tips.

24 PIN SSOP PACKAGE DRAWING

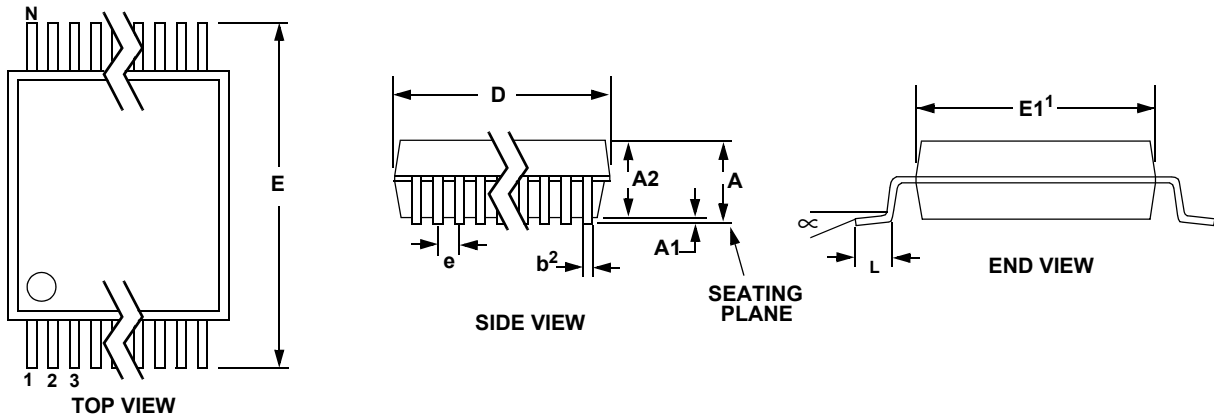

DIM	INCHES		MILLIMETERS		NOTE
	MIN	MAX	MIN	MAX	
A	--	0.084	--	2.13	
A1	0.002	0.010	0.05	0.25	
A2	0.064	0.074	1.62	1.88	
b	0.009	0.015	0.22	0.38	2,3
D	0.311	0.335	7.90	8.50	1
E	0.291	0.323	7.40	8.20	
E1	0.197	0.220	5.00	5.60	1
e	0.024	0.027	0.61	0.69	
L	0.025	0.040	0.63	1.03	
∞	0°	8°	0°	8°	

- Notes:
1. "D" and "E1" are reference datums and do not include mold flash or protrusions, but do include mold mismatch and are measured at the parting line, mold flash or protrusions shall not exceed 0.20 mm per side.
 2. Dimension "b" does not include dambar protrusion/intrusion. Allowable dambar protrusion shall be 0.13 mm total in excess of "b" dimension at maximum material condition. Dambar intrusion shall not reduce dimension "b" by more than 0.07 mm at least material condition.
 3. These dimensions apply to the flat section of the lead between 0.10 and 0.25 mm from lead tips.

Revisions

REVISION	DATE	CHANGES
PP1	Jan 1999	Initial release
PP6	Sep 2004	Added lead-free devices
F1	Jul 2005	Updated with most-current characterization data.

Contacting Cirrus Logic Support

For all product questions and inquiries contact a Cirrus Logic Sales Representative.

To find the one nearest to you go to www.cirrus.com

IMPORTANT NOTICE

Cirrus Logic, Inc. and its subsidiaries ("Cirrus") believe that the information contained in this document is accurate and reliable. However, the information is subject to change without notice and is provided "AS IS" without warranty of any kind (express or implied). Customers are advised to obtain the latest version of relevant information to verify, before placing orders, that information being relied on is current and complete. All products are sold subject to the terms and conditions of sale supplied at the time of order acknowledgment, including those pertaining to warranty, indemnification, and limitation of liability. No responsibility is assumed by Cirrus for the use of this information, including use of this information as the basis for manufacture or sale of any items, or for infringement of patents or other rights of third parties. This document is the property of Cirrus and by furnishing this information, Cirrus grants no license, express or implied under any patents, mask work rights, copyrights, trademarks, trade secrets or other intellectual property rights. Cirrus owns the copyrights associated with the information contained herein and gives consent for copies to be made of the information only for use within your organization with respect to Cirrus integrated circuits or other products of Cirrus. This consent does not extend to other copying such as copying for general distribution, advertising or promotional purposes, or for creating any work for resale.

CERTAIN APPLICATIONS USING SEMICONDUCTOR PRODUCTS MAY INVOLVE POTENTIAL RISKS OF DEATH, PERSONAL INJURY, OR SEVERE PROPERTY OR ENVIRONMENTAL DAMAGE ("CRITICAL APPLICATIONS"). CIRRUS PRODUCTS ARE NOT DESIGNED, AUTHORIZED OR WARRANTED FOR USE IN AIRCRAFT SYSTEMS, MILITARY APPLICATIONS, PRODUCTS SURGICALLY IMPLANTED INTO THE BODY, AUTOMOTIVE SAFETY OR SECURITY DEVICES, LIFE SUPPORT PRODUCTS OR OTHER CRITICAL APPLICATIONS. INCLUSION OF CIRRUS PRODUCTS IN SUCH APPLICATIONS IS UNDERSTOOD TO BE FULLY AT THE CUSTOMER'S RISK AND CIRRUS DISCLAIMS AND MAKES NO WARRANTY, EXPRESS, STATUTORY OR IMPLIED, INCLUDING THE IMPLIED WARRANTIES OF MERCHANTABILITY AND FITNESS FOR PARTICULAR PURPOSE, WITH REGARD TO ANY CIRRUS PRODUCT THAT IS USED IN SUCH A MANNER. IF THE CUSTOMER OR CUSTOMER'S CUSTOMER USES OR PERMITS THE USE OF CIRRUS PRODUCTS IN CRITICAL APPLICATIONS, CUSTOMER AGREES, BY SUCH USE, TO FULLY INDEMNIFY CIRRUS, ITS OFFICERS, DIRECTORS, EMPLOYEES, DISTRIBUTORS AND OTHER AGENTS FROM AND ALL LIABILITY, INCLUDING ATTORNEYS' FEES AND COSTS, THAT MAY RESULT FROM OR ARISE IN CONNECTION WITH THESE USES.

Cirrus Logic, Cirrus, and the Cirrus Logic logo designs are trademarks of Cirrus Logic, Inc. All other brand and product names in this document may be trademarks or service marks of their respective owners.

SPI is a trademark of Motorola, Inc.

Microwire is a trademark of National Semiconductor Corporation.